

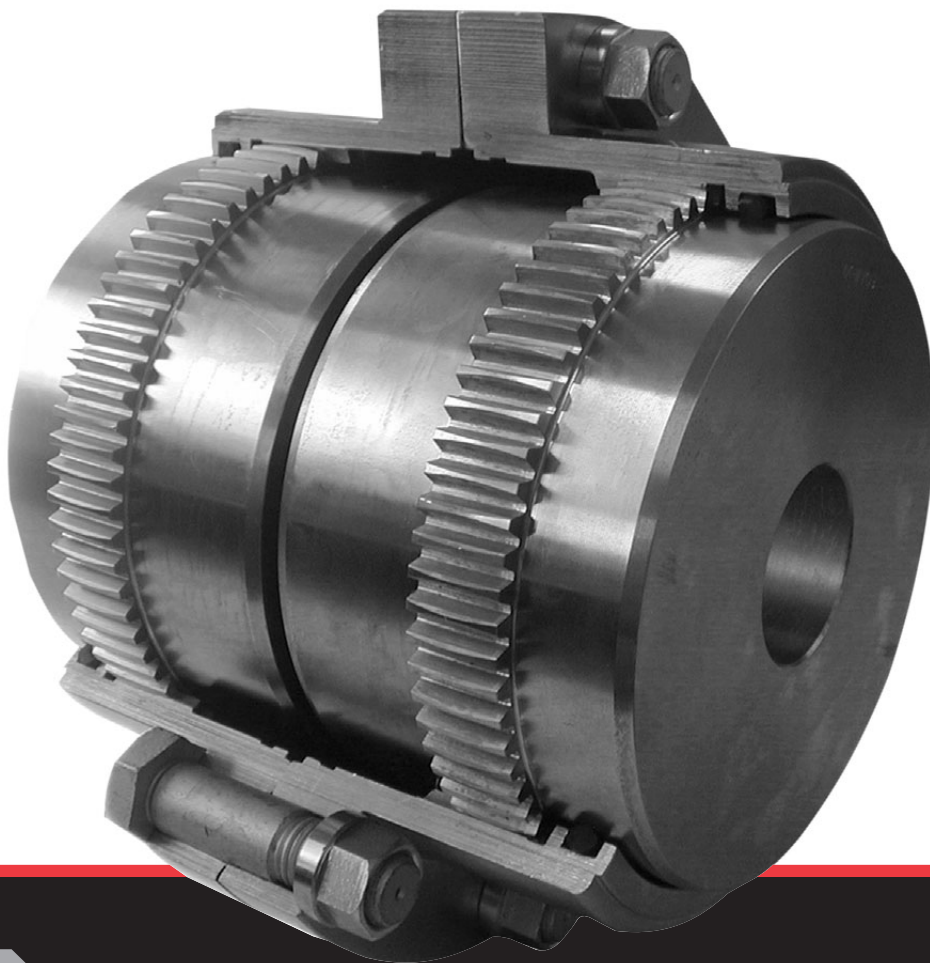

BEARING MAN GROUP



# FST - FLEXIBLE GEAR COUPLINGS

## Technical Catalogue



## Index

Introduction.....	1
Why Escogear?.....	2
Feature .....	3
Availabilities.....	4
Other types available- Shaft connections .....	5
How to select the right Escogear size.....	6-7
Equivalent chart.....	8
Interchangeability chart .....	9
Escogear FST.....	10-11
Escogear FFS.....	12
Escogear FSE.....	13
Escogear FMM .....	14
Escogear FDMM.....	15
Escogear FSH.....	16
Escogear FLE.....	17
Escogear FSP.....	18
Escogear FSV .....	19
Escogear FSLE.....	20
Escogear FRR.....	21
Escogear FWD .....	22
Escogear FET.....	23
Main features.....	24
Installation & Maintenance.....	25 - 27
Specific Protective Measures  .....	28

On the Industrial World Market, there are many different kinds of couplings for rotating equipment available.

These couplings can be divided into two major categories: the lubricated and the non lubricated types. Gear type couplings, which are of course of the lubricated type, are still dominating the Industrial market.

The reasons why gear type couplings still have a leading market position are directly related to the specific requirement of the various rotating machines in the medium to heavy industries such as the steel, pulp & paper and the cement industry.

Following these requirements, a coupling must:

PRESENT: the lowest torque/weight ratio.  
the highest torque/max. bore ratio.

ALLOW: the combination of important angular, radial and axial misalignment, at the same time.

BE ABLE: to rotate at high rotating speeds, without vibrations.  
to accept the largest possible assembly options to suit the design of the driver and the driven machine.

In this case, a gear type coupling is the ideal solution.



Series NST  
Torque: up to 2000 Nm  
Bore: up to 65 mm

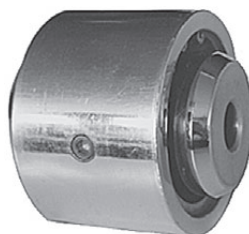

Series CST / ...M  
Torque: up to 174000 Nm  
Bore: up to 290 mm

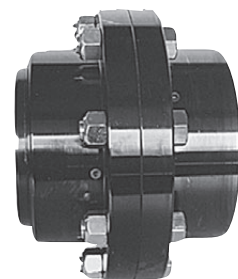

Series FST  
Torque: up to 5040000 Nm  
Bore: up to 1130 mm

## Why Escogear ?

### High Torque and Misalignment capacity

Thanks to the patented escogear **Multicrown** profile (used on the C and F series), the optimised coupling design and the standard use of 12.9 quality bolts, the Escogear couplings offer the user a **very high torque capacity**.

This means that for a given torque a smaller coupling can be used which results in more efficient machine design and performance. Furthermore, this high torque is available at **important angular misalignment**.

### Transparent coupling selection

The torque capacity of a gear type coupling strongly depends on the angular misalignment to which it is subjected: the higher the misalignment, the lower the torque capacity. It is clear that this relationship can and will cause problems in coupling selection because misalignment during operation is almost impossible to predict. Escogear couplings of the F and C...M type are equipped with Esco **Multicrown tooth form**. Thanks to this quite unique design, the escogear has a torque capacity that is practically independent of the angular misalignment. Therefore, coupling selection is **easy** and mistakes are avoided : long coupling life is guaranteed.

### High precision Gearing

Pitch error in the gearing of coupling can strongly affect, the load distribution between the teeth can be strongly influenced. In some cases, the maximum load applied on the teeth can be twice the value of the load calculated. The consequence will be higher surface and root stresses and coupling failure might be the result. Thanks to the high precision manufacturing process and equipment on which all escogear couplings are manufactured, and the sophisticated quality control, pitch error is minimized and the best possible gear quality level and life time can be guaranteed.

### Reduced backlash

One of the consequences of the **Multicrown** design is that the necessary backlash between the teeth can be reduced to an absolute minimum. This will reduce the impact loads in start/stop and reversing torque applications. As a result, the teeth can be designed with a larger section and the root stresses will be reduced. Thanks to this feature the escogear couplings are ideal for use in presses, mills, punching machines, portal cranes etc...

### Perfect gear top centring

Gear type couplings require, in order to operate, a "clearance" between the top of each hub tooth and the root of the sleeve teeth. Due to this clearance, the sleeve cannot be perfectly centred on the hubs. This will create vibrations in applications where the load constantly changes from no load to full load (e.g. portal cranes). These vibrations will of course influence the operation of the connected equipment. Thanks to special design and machining techniques, Esco is able to pilot the top of each hub tooth into the root of the sleeve teeth. By doing so, the sleeve will remain perfectly centred on the hub and vibrations will be avoided. This specific feature is standard on all F and C...M couplings.

### Excellent protection of components

In order to guarantee optimum operation, all escogear couplings are protected with special surface treatment or coating. All bolts are coated with Dacromet and the nuts are zinc plated which gives an excellent corrosion resistance and makes disassembly possible, even after numerous years of service life. Furthermore, all the steel components are protected with a special coating to improve their corrosion resistance.



# SERIES F

WITH ESCO MULTICROWN TOOTH FORM FOR LONG LIFE

Maximum torque: up to 5 040 000 Nm – Bore: up to 1 130 mm

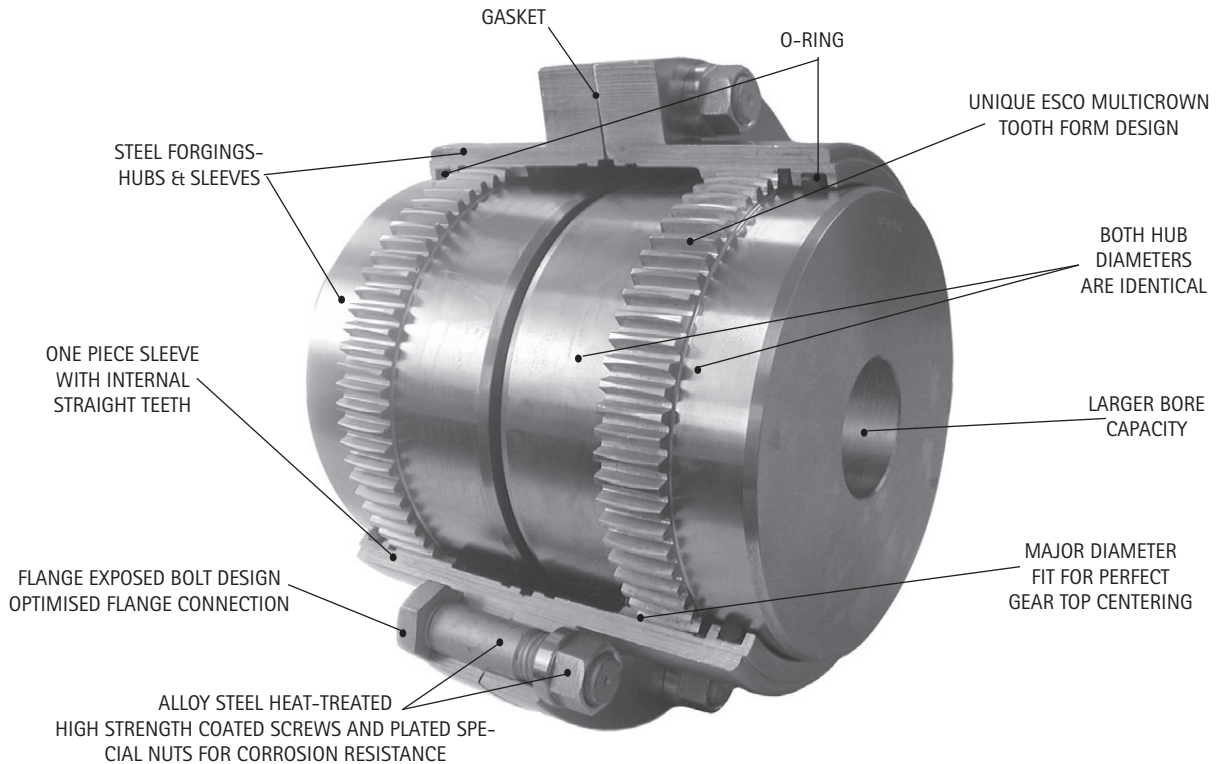

- LOWER STRESSES

The ESCO MULTICROWN tooth form is a curve with constantly changing radii of curvature. The tooth contact area under misaligned conditions has a much larger radius of curvature than conventional crowning. The contact area therefore is larger thus reducing the surface stresses.

- CONSTANT VELOCITY POWER TRANSMISSION

ESCO generates the ESCO MULTICROWN, tooth in such a way that the necessary characteristics for homocinetic conjugate tooth action are perfectly achieved.







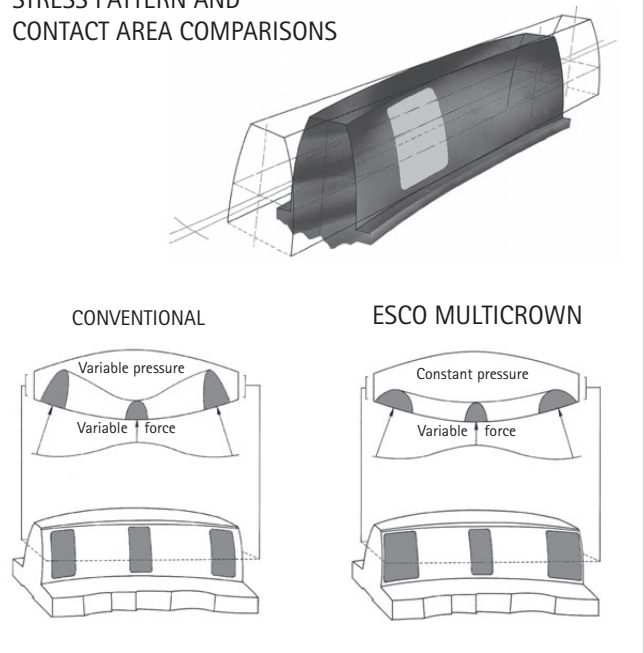



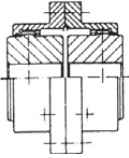

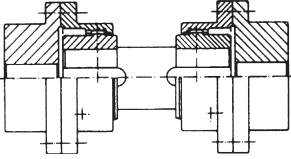
- LESS BACKLASH

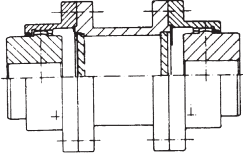

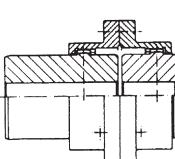

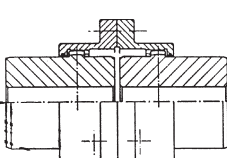

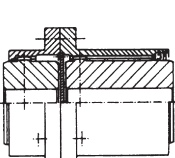

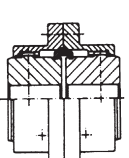

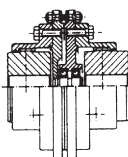
The ESCO MULTICROWN tooth design requires less backlash for a given angle of misalignment than the conventional crowning, thus reducing shocks in reversing application.

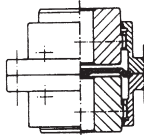
STRESS PATTERN AND CONTACT AREA COMPARISONS

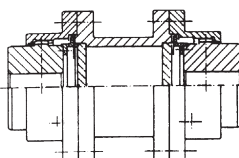

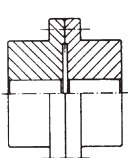
# AVAILABILITIES

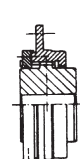
FST	 ← B410 & B411	
STANDARD		
FFS	 ← B412	
FLOATING SHAFT		
FSE	 ← B413	
SPACER EXECUTION		
FMM	 ← B414	
MILL-MOTOR		
FDMM	 ← B415	
DOUBLE MILL-MOTOR		
FSH	 ← B416	
SLIDING HUB		
FLE	 ← B417	
LIMITED EN FLOAT		

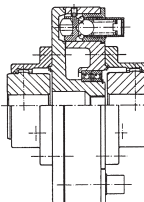
Bolts and nuts (metric)		Bolts and nuts (conform to AGMA 516.01)
Exposed metric "EM"		Exposed inch "EI"
FSP	 ← B418	
SHEAR PIN		
FSV	 ← B419	
STANDARD VERTICAL		
FSLE	 ← B420	
LIMITED END FLOAT		
FRR	 ← B421	
RIGID - RIGID		
FWD	 ← B422	
WINCH DRUM		
FET	 ← B423	
WITH ESCOTORQUE		

## OTHER TYPES AVAILABLE (on request)

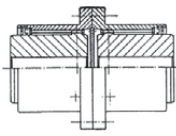
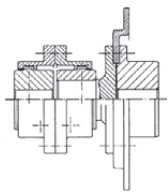
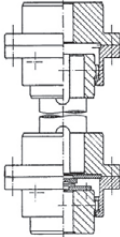
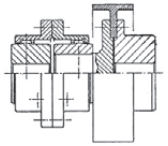
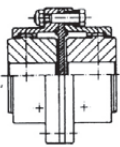
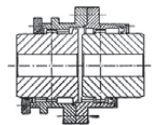
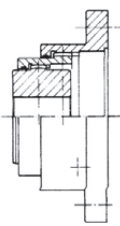
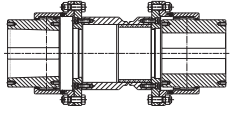
<p>FDSH DOUBLE SLIDING-HUB</p>		<p>FBD WITH BRAKE DISC</p>	
<p>FFSV VERTICAL FLOATING-SHAFT</p>		<p>FBP WITH BRAKE-PULLEY</p>	
<p>FIN INSULATED</p>		<p>FCO CUT-OUT</p>	
<p>FFA TO BE ADAPTED ON FLYWHEEL OR FLANGE</p>		<p>FSESP SHEAR SPACER</p>	

Only a few special types of couplings are illustrated. Additional special types are available on request.

## SHAFT CONNECTIONS

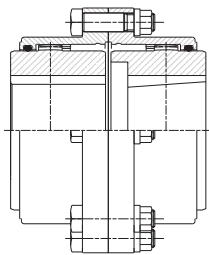

KEYWAY

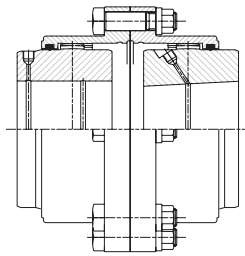

INTERFERENCE FIT

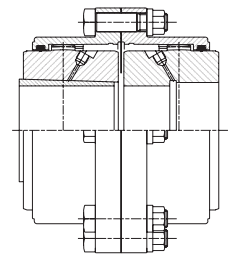

INTERFERENCE WITH  
INTERMEDIATE CONICAL BUSHING

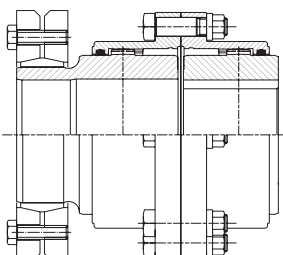

EXTERNAL CLAMPING

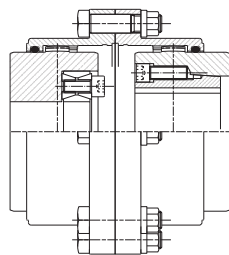

INTERNAL CLAMPING

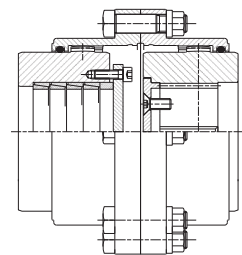

SPLINES

## HOW TO SELECT THE RIGHT COUPLING SIZE

A. Select the size of ESCOGEAR coupling that will accommodate the largest shaft diameter.

B. Make sure this coupling has the required torque capacity according to following formula:  $\text{torque in Nm} = \frac{9550 \times P \times F_u \times F_{\epsilon_x}}{n}$

P = power in kW; n = speed in rpm;  $F_u$  = service factor according to tabulation 1.

$F_{\epsilon_x} = 2$  in case of use in potentially explosive atmospheres  $\epsilon_x$ , European Directive 94/9/EC. In normal atmospheres,  $F_{\epsilon_x} = 1$ .

The coupling selected per (A) must have an equal or greater torque capacity than the result of the formula (B). If not select a larger size coupling. Check if application peak torque does not exceed tabulated peak torque  $T_p$  indicated planographs B410 to B423. Check also max. allowable misalignment using the graph of tabulation 2.

C. Check if shaft/hub connection will transmit the torque. If necessary, select a longer hub.

D. Read carefully assembly and maintenance instructions IM/B400.

DRIVEN MACHINE		APPLICATIONS	DRIVER MACHINE		
			Electric motors Turbines	Hydraulic motors Gears drivers	Reciprocating engine Electric motors frequent starts
UNIFORM	Generators - Blowers: centrifugal vane, fans - Centrifugal pumps and compressors - Machine tools: auxiliary drives - Conveyors: belt and chain, uniformly loaded, escalators - Can filling machines and bottling machinery - Agitators: pure liquids.	Service factor $F_u$			
		0,8 to 1,25	1 to 1,5	1,25 to 1,75	
	Propeller - Waterjet pumps	1,25	1,5	1,75	
MODERATE SHOCKS	Blowers: lobe - Pumps: gear and lobe types - Vane compressors - Machine tools: main drives - Conveyors: belt and chain not uniformly fed bucket and screw - Elevators, cranes, tackles and winches - Wire winding machines, reels, winders (paper industry) - Agitators liquids and solids, liquids variable density.	1,25 to 1,5	1,5 to 1,75	1,75 to 2	
HEAVY SHOCKS	Generators (welding) - Reciprocating pumps and compressors - Laundry washers - Bending roll, punch press, tapping machines - Barkers, calanders, paper presses - Briquetter machines, cement furnace - Crushers: ore and stone, hammer mill, rubber mill - Metal mills: forming machines, table conveyors - Draw Bench, wire drawing and flattening machines - Road & railroad equipment.	1,5 to 2	1,75 to 2,25	2 to 2,5	

### 1) MAXIMUM MISALIGNMENT

TABULATION 2

GRAPH (T, n)

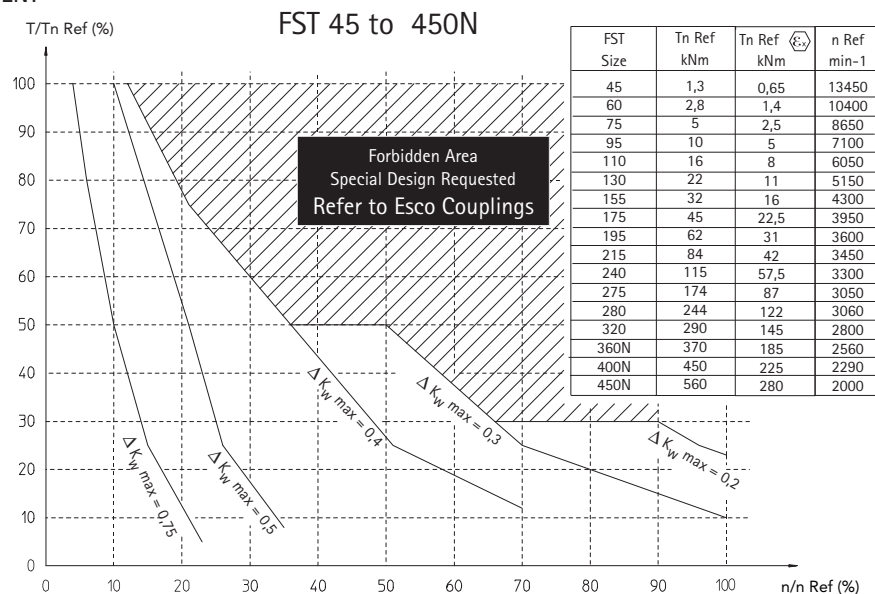

#### HOW TO USE THE GRAPH (T,n) ?

Maximum torque, maximum speed and maximum misalignment may not occur simultaneously.

Graph must be used as follows:

1. Calculate  $T_n$  and  $T_p$  and select coupling size as usual.  $T_n$  = nominal torque;  $T_p$  = peak torque
2. Calculate  $T_n/T_n\text{Ref}$  and  $n/n\text{Ref}$  and plot the resulting point in the graph.
3. If the resulting point is located in the white area, a standard coupling may be used as far as maximum misalignment doesn't exceed the maximum misalignment indicated in the graph.
4. If the resulting point is located in the shaded area, refer to ESCO COUPLINGS
5. In case of use in potentially explosive atmospheres  $\epsilon_x$ , proceed the same way but using  $T_n\text{Ref}_{\epsilon_x}$  for the calculation. Max misalignment may not exceed 0,5° per gear mesh.

2) MINIMUM MISALIGNMENT =  $\Delta K_{Wmin} = 0,1^\circ$

### 3) MISALIGNMENT CONTROL

1- Measure X (TIR) - 2- Measure Y-Z - 3- Verify the relationship for the misalignment control:  $\Delta K_{Wmin} \leq \frac{X}{K_x} + \frac{Y-Z}{K_y} \leq 0,75 \times \Delta K_{Wmax}$

$$K_x = K_{x0} + \frac{S}{30} \quad \text{with } S = \text{Spacer length (mm)}$$

(If no spacer:  $S = 0$ )

$$K_y = K_{y0}$$

FST	$K_{x0}$	$K_{y0}$
45	1,92	2,34
60	2,06	3,04
75	2,76	3,71
95	3,25	4,54
110	3,80	5,28
130	4,47	6,22
155	5,03	7,55
175	5,72	8,20
195	6,35	9,18
215	7,47	9,98
240	8,24	11,04
275	9,18	12,98
280	10,82	13,76
320	11,34	15,08
360	12,32	16,76
400	13,37	18,50
450	14,35	20,74

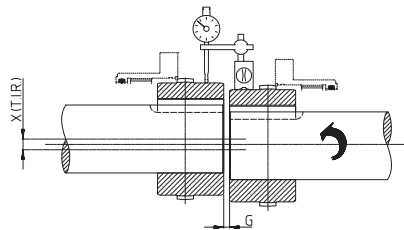
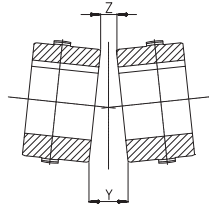

#### 4) EXAMPLES:

##### Calculation

$$\left. \begin{array}{l} T/Tn \text{ ref} = 30\% \\ n/n \text{ ref} = 30\% \end{array} \right\} \Delta K_{Wmax} = 0,4^\circ$$

FST 175:  $K_x = 5,72 \quad K_y = 8,2$

##### Measurement

$$X \text{ (TIR)} = 0,9 \text{ mm} \quad Y-Z = 0,4 \text{ mm}$$

##### Control

Formule:

$$\Delta K_{Wmin} \leq \frac{X}{K_x} + \frac{Y-Z}{K_y} \leq 0,75 \times \Delta K_{Wmax}$$

$$\text{Calculation : } 0,1^\circ \leq \frac{0,9}{5,7} + \frac{0,4}{8,2} \leq 0,75 \times 0,4 \quad \text{ok}$$

LEGEND OF USED PICTOGRAMS		Notes for series F	
	MAXIMUM NOMINAL BORE (mm)	<ol style="list-style-type: none"> <li>1 For key according to ISO R 773.</li> <li>2 Gear maximum continuous transmissible torque for the tabulated misalignment. The effective transmissible torque depends on the bore and shaft/hub connection.</li> <li>3 Higher speed on special request.</li> <li>3.1 For grease withstanding centrifugal acceleration of 1.000g. See installation and maintenance manual IM.</li> <li>3.2 For grease withstanding centrifugal acceleration of 2.000g. See installation and maintenance manual IM.</li> <li>3.3 Depends on S.</li> <li>3.4 For long operation in disconnected position contact us.</li> <li>4 For solid bore.</li> <li>4.1 Depends on S.</li> <li>4.2 For solid bore and S minimum.</li> <li>4.3 Per 100 mm spacer length.</li> <li>4.4 Depends on L and R.</li> <li>5 For pilot bored hubs.</li> <li>5.1 Depends on S.</li> <li>5.2 For pilot bored hubs and S minimum.</li> <li>5.3 Per 100 mm spacer length.</li> <li>5.4 Depends on L and R.</li> <li>6 See installation and maintenance manual IM.</li> <li>6.1 Depends on S. Values given for S maximum.</li> <li>7 On request. For larger S contact us.</li> <li>8 Values for S minimum. S maximum depends on torque and speed.</li> <li>9 G must remain constant during operation.</li> <li>10 Needed to control the alignment and inspect the gears.</li> </ol>	
	MINIMUM BORE (mm)		
	MAXIMUM BORE (mm)		
	Tn		MAXIMUM NOMINAL TORQUE (Nm)
	Tp		MAXIMUM PEAK TORQUE (Nm)
	MAXIMUM SPEED (rpm)		
	MAXIMUM OFFSET (mm)		
	MAXIMUM ANGULAR MISALIGNMENT (degree)		
	INERTIA (kgm²)		
	WEIGHT (kg)		
	GREASE QUANTITY (dm³)		

\* Max. torque, speed and misalignment tabulated values may not be cumulated  
See IM/B400.

Torque Capacity (Nm)	Escogear FST (2 x 0,75°)	Flender Zapex (2 x 0,5°)	Maina GO-A (2 x 0,5°)	Jaure MT Series (2 x 0,5°)	Falk Lifelign (2 x 0,5°)	Kopflex Series H
175000						
150000						
125000	FST 275		GO-A 11			
100000	FST 240	ZIN 7	GO-A 10	MT 260	1070G	7H
80000	FST 215	ZIN 6		MT 230	1060G	
60000	FST 195	ZIN 5,5	GO-A9	MT 205	1055G	6H
40000	FST 175	ZIN 5	GO-A 8	MT 185	1050G	5,5H
30000	FST 155	ZIN 4,5	GO-A 7	MT 165	1045G	5H
20000	FST 130	ZIN 4	GO-A 6	MT 145	1040G	4,5H
15000	FST 110	ZIN 3,5	GO-A 5	MT 125	1035G	4H
10000						
7500	FST 95	ZIN 3	GO-A 4	MT 100	1030G	3H
5000						
3500	FST 75	ZIN 2,5	GO-A 3	MT 90	1025G	2,5H
2500						
2000	FST 60	ZIN 2	GO-A 2	MT 70	1020G	2H
1500						
1250		ZIN 1,5	GO-A 1	MT 55	1015G	1,5H
1000						
750	FST 45	ZIN 1	GO-A 0	MT 42	1010G	1H
500						

Remark: When selecting based upon the above equivalent chart, please check bore capacity of escogear coupling against the application requirements.

ESCO	LOVEJOY	FALK	KOP-FLEX	AMERIDRIVES	AJAX
FST	F	G20, G10	H	F	6901
45	1	1010	1	101	1
60	1 1/2	1015	1 1/2	101 1/2	1,5
75	2	1020	2	102	2
95	2 1/2	1025	2 1/2	102 1/2	2,5
110	3	1030	3	103	3
130	3 1/2	1035	3 1/2	103 1/2	3,5
155	4	1040	4	104	4
175	4 1/2	1045	4 1/2	104 1/2	4,5
195	5	1050	5	105	5
215	5 1/2	1055	5 1/2	105 1/2	5,5
240	6	1060	6	106	6
275	7	1070	7	107	7

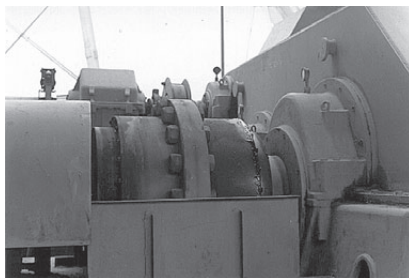

Cement kiln mill drive

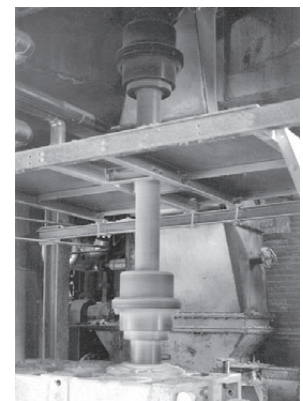

Vertical mixer drive

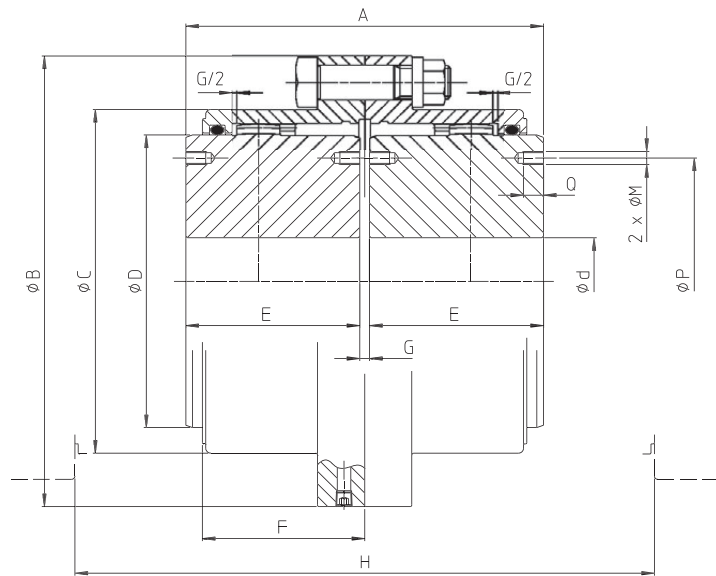

←A150			Type FST												
			45	60	75	95	110	130	155	175	195	215	240	275	
	d Ø nominal max.	mm	45	60	75	95	110	130	155	175	195	215	240	275	
	d Ø min.	mm	0	0	0	0	0	55	65	80	90	100	120	150	
	* d Ø max.	mm	50	64	78	98	112	132	158	175	198	217	244	275	
	Tn	Nm	1300	2800	5000	10000	16000	22000	32000	45000	62000	84000	115000	174000	
	Tp		2600	5600	10000	20000	32000	44000	64000	90000	124000	168000	230000	348000	
	3.1	tr/min omw/min	5000	4400	4000	3600	3350	3100	2800	2700	2550	2450	2300	2150	
	3.2	rpm min <sup>-1</sup>	7000	6200	5650	5100	4700	4350	4000	3800	3600	3450	3300	3050	
	—	degré graad degree Grad	2x0,75	2x0,75	2x0,75	2x0,75	2x0,75	2x0,75	2x0,75	2x0,75	2x0,75	2x0,75	2x0,75	2x0,75	
	—	mm: ±	0,35	0,4	0,5	0,6	0,7	0,9	1	1,1	1,2	1,4	1,5	1,7	
	4	J (WR <sup>2</sup> )	0,005	0,015	0,040	0,105	0,191	0,430	0,842	1,320	2,448	3,716	5,384	10,872	
	5	kg	4,1	8,0	14,6	26,1	38,8	59,2	89,4	117,5	167,1	222,4	275,0	413,6	
	6	dm <sup>3</sup>	0,05	0,07	0,13	0,21	0,36	0,52	0,80	0,98	1,51	2,02	2,43	3,29	
mm: ±	A	mm	89	103	127	157	185	216	246	278	308	358	388	450	
	B	mm	111	141	171	210	234	274	312	337	380	405	444	506	
	C	mm	80	103,5	129,5	156	181	209	247	273	307	338	368	426	
	D	mm	67	87	106	130	151	178	213	235	263	286	316	372	
	E	mm	43	50	62	76	90	105	120	135	150	175	190	220	
	F	mm	41	47	58,5	68,5	82	98	108,5	121	132	151,5	165	183,5	
	G	mm	3	3	3	5	5	6	6	8	8	8	8	10	
	H	10	mm	147	166	212	249	295	350	392	440	484	562	616	688
	M	mm									M 12	M 16	M 16	M 16	M 20
	P	mm									205	226	250	276	330
	Q	mm									18	24	24	24	30

\* Consult us

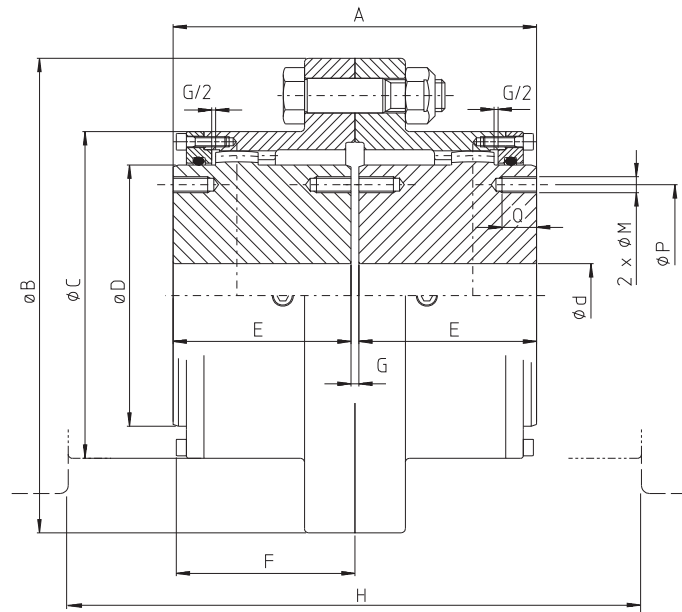

max. 1,5°

←A150		Type FST																
		280	320	360N	400N	450N	500	530	560	600	660	730	830	900	1000	1060	1130	
	d Ø nominal max.	mm	280	320	360	400	450	500	530	560	600	660	730	830	900	1000	1060	1130
	d Ø min.	mm	180	200	220	260	280	300	330	350	380	420	480	540	580	640	680	740
	* d Ø max.	mm	310	340	375	420	470	500	530	560	600	660	730	830	900	1000	1060	1130
	Tn	Nm	244000	290000	370000	450000	560000	630000	750000	860000	1020000	1290000	2020000	2450000	3070000	3610000	4390000	5040000
	1m Tp	Nm	488000	580000	740000	900000	1120000	1260000	1500000	1720000	2040000	2580000	4040000	4900000	6140000	7220000	8780000	10080000
	/min,max.	tr/min omw/min rpm min <sup>-1</sup>	1900	1800	1500	1400	1300	1150	1050	900	800	550	450	380	325	280	240	220
			2x0,75	2x0,75	2x0,75	2x0,75	2x0,75	2x0,75	2x0,75	2x0,75	2x0,75	2x0,75	2x0,75	2x0,75	2x0,75	2x0,75	2x0,75	2x0,75
	mm: ±	2	2,1	2,3	2,5	2,7	2,8	3	3,2	3,4	3,6	3,7	4	4,4	4,8	5,2	5,4	
			4	kgm <sup>2</sup>	20,1	31	45	68	105	164	228	313	430	685	1161	1756	2580	3690
	kg	5	591	760	932	1180	1532	1950	2330	2840	3370	4370	6110	7810	9730	11860	14220	16380
				dm <sup>3</sup>	6	6,44	7,6	11	12	16	18	23	25	29	39	57	77	105
mm: ±	A	mm				570	597	623	673	713	759	809	859	905	945	1105	1205	1285
	B	mm	591	640	684	742	804	908	965	1029	1092	1200	1330	1440	1545	1650	1750	1860
	C	mm	472	518	562	620	682	733	787	841	892	997	1130	1240	1345	1450	1550	1660
	D	mm	394	432	480	530	594	629	673	724	772	870	965	1062	1156	1254	1346	1448
	E	mm	280	292	305	330	350	370	395	420	440	460	540	590	630	670	690	700
	F	mm	225	234	251	269	283	301	318	333	361	375	408	448	483	528	538	548
	G	mm	10	13	13	13	13	19	19	19	25	25	25	25	25	25	25	25
	H	10 mm	632	660	705	745	770	825	870	900	990	1020	1130	1210	1290	1400	1420	1440
	M	mm	M 20	M 20	M 24	M 24	M 24	M 42	M 42	M 42	M 48	M 48	M 48	M 48	M 48	M 48	M 48	M 48
	P	mm	336	377	420	480	544	568	600	642	680	765	860	950	1040	1130	1230	1300
Q	mm	30	30	40	40	40	76	76	76	82	82	82	82	82	82	82	82	

\* Consult us

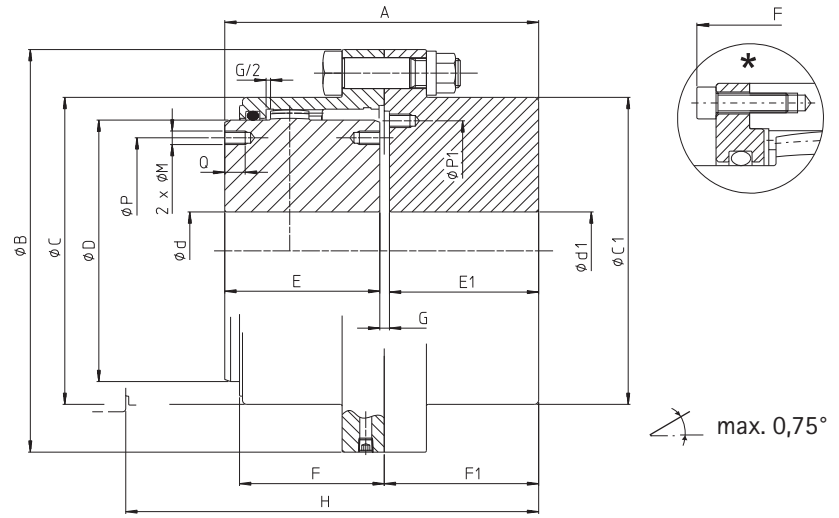
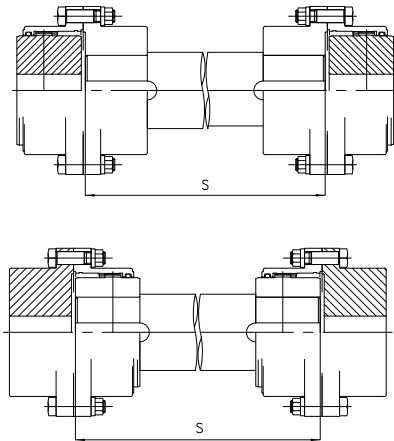

		Type FFS														
			45	60	75	95	110	130	155	175	195	215	240	275	* 280	* 320
	d Ø nominal max.	mm	45	60	75	95	110	130	155	175	195	215	240	275	280	320
	d Ø min.	mm	0	0	0	0	0	55	65	80	90	100	120	150	180	200
	* d Ø max.	mm	50	64	78	98	112	132	158	175	198	217	244	290	310	340
	Ø max.	mm	55	75	95	110	130	155	180	200	230	250	280	330	360	400
	Ø min.	mm	0	0	0	0	0	55	65	80	90	100	120	150	180	200
	Tn	Nm	1300	2800	5000	10000	16000	22000	32000	45000	62000	84000	115000	174000	244000	290000
	Tp	Nm	2600	5600	10000	20000	32000	44000	64000	90000	124000	168000	230000	348000	488000	580000
	min.max.	tr/min omw/min rpm min <sup>-1</sup>														
	α	degré graad degree Grad	0,75	0,75	0,75	0,75	0,75	0,75	0,75	0,75	0,75	0,75	0,75	0,75	0,75	0,75
	J (WR <sup>2</sup> )	kgm <sup>2</sup>	0,005	0,016	0,040	0,107	0,197	0,446	0,868	1,362	2,584	3,900	5,650	11,446	22,6	34,5
		kg	4,1	8,2	14,6	26,5	39,6	60,3	90,3	119,0	174,3	231,1	285,2	429,3	648	822
		dm <sup>3</sup>	0,023	0,037	0,065	0,104	0,181	0,261	0,398	0,488	0,756	1,009	1,215	1,643	3,2	3,8
mm: ±	A	mm	88	102	125	156	183	212,5	239,5	272	308	358	390	453	573	598,5
	B	mm	111	141	171	210	234	274	312	337	380	405	444	506	591	640
	C	mm	80	103,5	129,5	156	181	209	247	273	307	338	368	426	472	518
	C1	mm	80	103,5	126	152	178	208	245	270	305	330	362	416		
	D	mm	67	87	106	130	151	178	213	235	263	286	316	372	394	432
	E	mm	43	50	62	76	90	105	120	135	150	175	190	220	280	292
	E1	mm	40	47	58	74	87	101	113	129	150	175	190	220	280	292
	F	mm	41	47	58,5	68,5	82	98	108,5	121	132	151,5	165	183,5	225	234
	F1	mm	43,5	50,5	61,5	77,5	90,5	104,5	116,5	133	154	179	196	228	288	300
	G	mm	5	5	5	6	6	6,5	6,5	8	8	8	10	13	13	14,5
	H	mm	117	133,5	167,5	202	238	279,5	312,5	353	396	460	504	572	606	637
	M	mm								M 12	M 16	M 16	M 16	M 20	M 20	M 20
	P	mm								205	226	250	276	330	336	377
	P1	mm								235	265	290	320	370	416	456
Q	mm								18	24	24	24	30	30	30	

\* Consult us

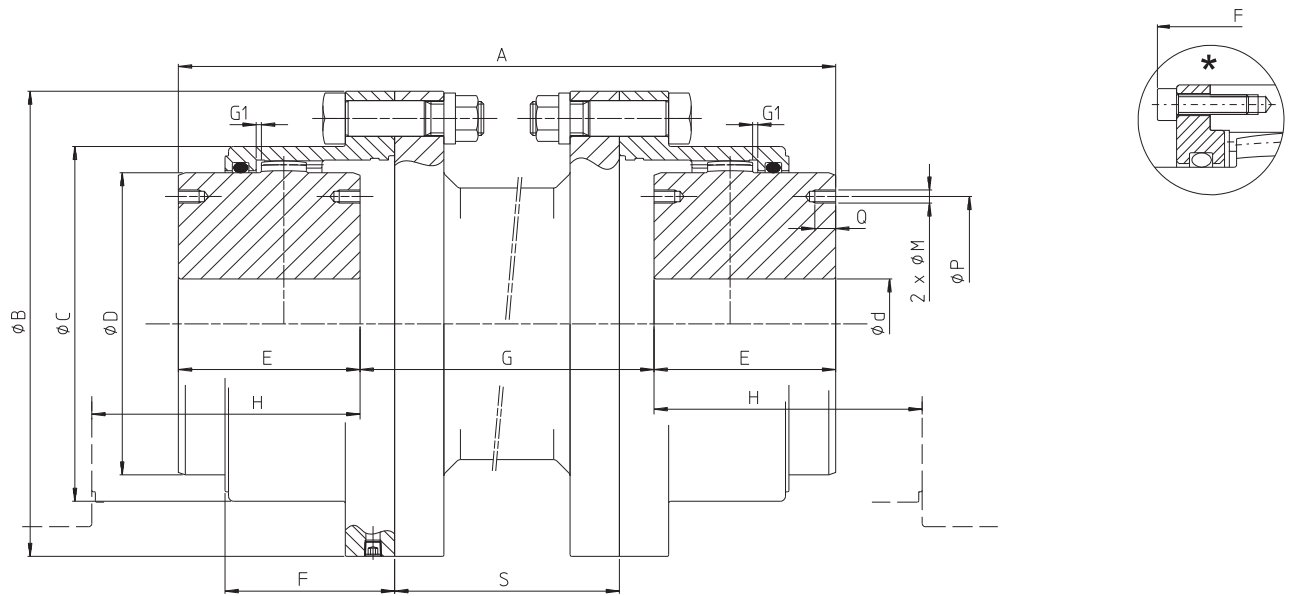

max. 1,5°

←A150			Type FSE														
			45	60	75	95	110	130	155	175	195	215	240	275	* 280	* 320	
	d Ø nominal max.	mm	45	60	75	95	110	130	155	175	195	215	240	275	280	320	
		d Ø min.	mm	0	0	0	0	55	65	80	90	100	120	150	180	200	
		* d Ø max.	mm	50	64	78	98	112	132	158	175	198	217	244	290	310	340
	Nm	Tn	1300	2800	5000	10000	16000	22000	32000	45000	62000	84000	115000	174000	244000	290000	
		Tp	2600	5600	10000	20000	32000	44000	64000	90000	124000	168000	230000	348000	488000	580000	
	tr/min omw/min rpm min <sup>-1</sup>	3.3															
	degré graad degree Grad	-	2x0,75	2x0,75	2x0,75	2x0,75	2x0,75	2x0,75	2x0,75	2x0,75	2x0,75	2x0,75	2x0,75	2x0,75	2x0,75	2x0,75	
	J (WR <sup>2</sup> )	4.1															
	kg	5.1															
	dm <sup>3</sup>	6	2x0,025	2x0,037	2x0,065	2x0,105	2x0,18	2x0,26	2x0,40	2x0,49	2x0,76	2x1,01	2x1,21	2x1,64	2x3,2	2x3,8	
min.	A	8	mm	167	195	245	291	323	380	412	450	516	580	624	676	780	827
	B		mm	111	141	171	210	234	274	312	337	380	405	444	506	591	640
	C		mm	80	103,5	129,5	156	181	209	247	273	307	338	368	426	472	518
	D		mm	67	87	106	130	151	178	213	235	263	286	316	372	394	432
	E		mm	43	50	62	76	90	105	120	135	150	175	190	220	280	292
	F		mm	41	47	58,5	68,5	82	98	108,5	121	132	151,5	165	183,5	225	234
	G	8	mm	81	95	121	139	143	170	172	180	216	230	244	236	226	243
	H	10	mm	63	76	91	110	131	155	175	195	214	246	266	306	305	320
	M		mm								M 12	M 16	M 16	M 16	M 20	M 20	M 20
	P		mm								205	226	250	276	330	336	377
Q		mm								18	24	24	24	30	30	30	
min	S	8	mm	60	80	90	110	110	130	130	160	160	160	160	160	176	190
	G1		mm	1,5	1,5	1,5	2,5	2,5	3	3	4	4	4	4	5	5	6,5

\* Consult us

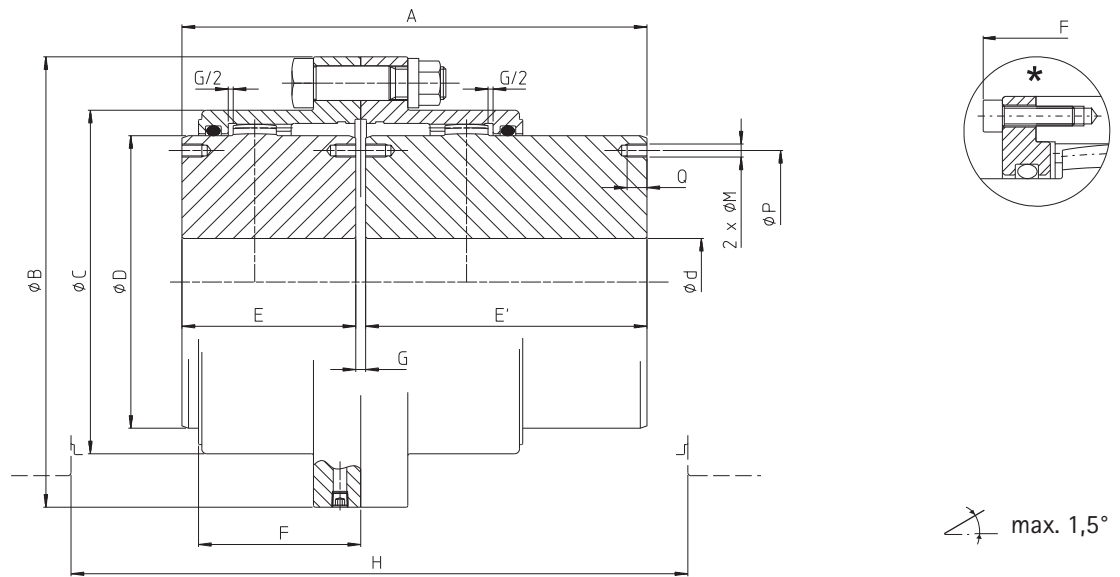

←A150		Type FMM															
		45	60	75	95	110	130	155	175	195	215	240	275	* 280	* 320		
	d Ø nominal max.	mm	45	60	75	95	110	130	155	175	195	215	240	275	280	320	
	d Ø min.	mm	0	0	0	0	0	55	65	80	90	100	120	150	180	200	
	* d Ø max.	mm	50	64	78	98	112	132	158	175	198	217	244	290	310	340	
	Tn	Nm	1300	2800	5000	10000	16000	22000	32000	45000	62000	84000	115000	174000	244000	290000	
	1m Tp		2600	5600	10000	20000	32000	44000	64000	90000	124000	168000	230000	348000	488000	580000	
	3.1	tr/min omw/min rpm min <sup>-1</sup>	5000	4400	4000	3600	3350	3100	2800	2700	2550	2450	2300	2150	1900	1800	
	3.2		7000	6200	5650	5100	4700	4350	4000	3800	3600	3450	3300	3050	2950	2800	
	—	degré graad degree Grad	2x0,75	2x0,75	2x0,75	2x0,75	2x0,75	2x0,75	2x0,75	2x0,75	2x0,75	2x0,75	2x0,75	2x0,75	2x0,75	2x0,75	
	—	mm: ±	0,35	0,4	0,5	0,6	0,7	0,9	1	1,1	1,2	1,4	1,5	1,7	2	2,1	
	J (WR <sup>2</sup> )	kgm <sup>2</sup>	0,005	0,018	0,047	0,121	0,221	0,480	0,953	1,47	2,71	4,10	6,07	12,79	22,4	35,6	
		kg	5,1	11,0	19,3	33,4	49,3	70,7	107	137	193	256	322	506	689	920	
	Grease	dm <sup>3</sup>	0,05	0,07	0,13	0,21	0,36	0,52	0,80	0,98	1,51	2,02	2,43	3,29	6,44	7,6	
mm: ±	A	mm	126	167	195	227	260	281	316	343	378	433	478	580	700	775	
	B	mm	111	141	171	210	234	274	312	337	380	405	444	506	591	640	
	C	mm	80	103,5	129,5	156	181	209	247	273	307	338	368	426	472	518	
	D	mm	67	87	106	130	151	178	213	235	263	286	316	372	394	432	
	E	mm	43	50	62	76	90	105	120	135	150	175	190	220	280	292	
	E'	mm	80	114	130	146	165	170	190	200	220	250	280	350	410	470	
	F	mm	41	47	58,5	68,5	82	98	108,5	121	132	151,5	165	183,5	225	234	
	G	mm	3	3	3	5	5	6	6	8	8	8	8	10	10	13	
	H	10	mm	157	200	239	276	318	351	392	440	484	562	616	704	765	805
	M	mm									M 12	M 16	M 16	M 16	M 20	M 20	M 20
	P	mm									205	226	250	276	330	336	377
Q	mm									18	24	24	24	30	30	30	



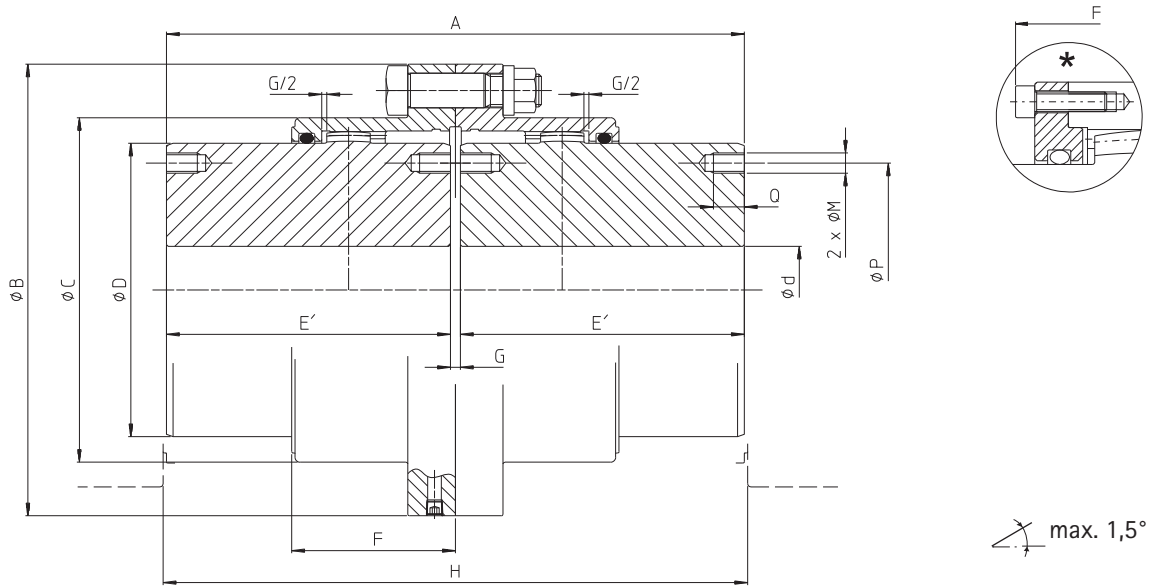



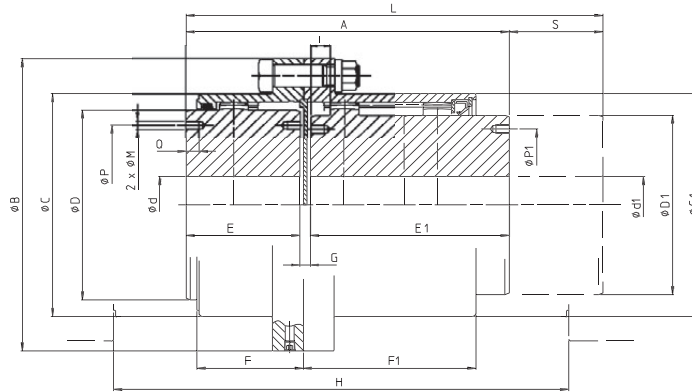

\* Consult us



←A150		Type FDMM															
		45	60	75	95	110	130	155	175	195	215	240	275	* 280	* 320		
	d Ø nominal max.	mm	45	60	75	95	110	130	155	175	195	215	240	275	280	320	
	d Ø min.	mm	0	0	0	0	0	55	65	80	90	100	120	150	180	200	
	* d Ø max.	mm	50	64	78	98	112	132	158	175	198	217	244	290	310	340	
	Tn	Nm	1300	2800	5000	10000	16000	22000	32000	45000	62000	84000	115000	174000	244000	290000	
	Tp		2600	5600	10000	20000	32000	44000	64000	90000	124000	168000	230000	348000	488000	580000	
	3.1	tr/min omw/min rpm min <sup>-1</sup>	5000	4400	4000	3600	3350	3100	2800	2700	2550	2450	2300	2150	1900	1800	
	3.2		7000	6200	5650	5100	4700	4350	4000	3800	3600	3450	3300	3050	2950	2800	
	—	degré graad degree Grad	2x0,75	2x0,75	2x0,75	2x0,75	2x0,75	2x0,75	2x0,75	2x0,75	2x0,75	2x0,75	2x0,75	2x0,75	2x0,75	2x0,75	
	—	mm: ±	0,35	0,4	0,5	0,6	0,7	0,9	1	1,1	1,2	1,4	1,5	1,7	2	2,1	
	4	kgm <sup>2</sup>	0,006	0,021	0,053	0,136	0,251	0,530	1,06	1,62	2,96	4,49	6,76	14,70	24,7	40,2	
	5	kg	6,1	14,0	24,0	40,7	59,9	82,1	125	157	220	289	370	599	787	1080	
	6	dm <sup>3</sup>	0,05	0,07	0,13	0,21	0,36	0,52	0,80	0,98	1,51	2,02	2,43	3,29	6,44	7,6	
mm: ±	A	mm	163	231	263	297	335	346	386	408	448	508	568	710	830	953	
	B	mm	111	141	171	210	234	274	312	337	380	405	444	506	591	640	
	C	mm	80	103,5	129,5	156	181	209	247	273	307	338	368	426	472	518	
	D	mm	67	87	106	130	151	178	213	235	263	286	316	372	394	432	
	E'	mm	80	114	130	146	165	170	190	200	220	250	280	350	410	470	
	F	mm	41	47	58,5	68,5	82	98	108,5	121	132	151,5	165	183,5	225	234	
	G	mm	3	3	3	5	5	6	6	8	8	8	8	10	10	13	
	H	10	mm	163	231	263	297	335	350	392	440	484	562	616	710	895	935
	M	mm								M 12	M 16	M 16	M 16	M 20	M 20	M 20	
	P	mm								205	226	250	276	330	336	377	
Q	mm								18	24	24	24	30	30	30		

\* Consult us



 ←A150			Type FSH										
			60	75	95	110	130	155	175	195	215		
	d Ø nominal max.	mm	60	75	95	110	130	155	175	195	215		
	d Ø min.	mm	0	0	0	0	55	65	80	90	100		
	* d Ø max	mm	64	78	98	112	132	158	175	198	217		
	d1 Ø max.	mm	0	0	0	0	55	65	80	90	100		
	Ø min.	mm	55	70	85	100	120	140	170	190	210		
	Tn	Nm	2800	5000	10000	16000	22000	32000	45000	62000	84000		
	1m Tp		5600	10000	20000	32000	44000	64000	90000	124000	168000		
	min.max.	tr/min omw/min rpm min <sup>-1</sup>											
		degré graad degree Grad											
	J (WR <sup>2</sup> )	kgm <sup>2</sup>											
		kg											
		dm <sup>3</sup>											
max.	A	6.1	mm	193	210	231	250	276	291	319	344	381	
	B		mm	141	171	210	234	274	312	337	380	405	
	C		mm	103,5	129,5	156	181	209	247	273	307	338	
	C1		mm	108	129,5	156	181	209	247	270	305	330	
	D		mm	87	106	130	151	178	213	235	263	286	
	D1		mm	78	98	115	140	165	195	230	260	280	
	E		mm	50	62	76	90	105	120	135	150	175	
	E1	6.1	mm	135	140	145	150	160	160	170	180	190	
max.	F		mm	47	58,5	68,5	82	98	108,5	121	132	151,5	
	F1	6.1	mm	138	139	144	157	159	162	168	168	179	
min.	G	min	mm	8	8	10	10	11	11	14	14	16	
max.	H	10	mm	247	276	300	330	370	385	425	460	510	
	I		mm	10	10	10	10	10	10	15	15	15	
max.	L	6.1	mm	278	290	311	340	361	371	394	414	451	
	M		mm							M12	M 12	M 16	
	P		mm							205	226	250	
	P1		mm							200	225	245	
	Q		mm							18	18	24	
	max.	S	7	mm	85	80	80	90	85	80	75	70	70

\* Consult us

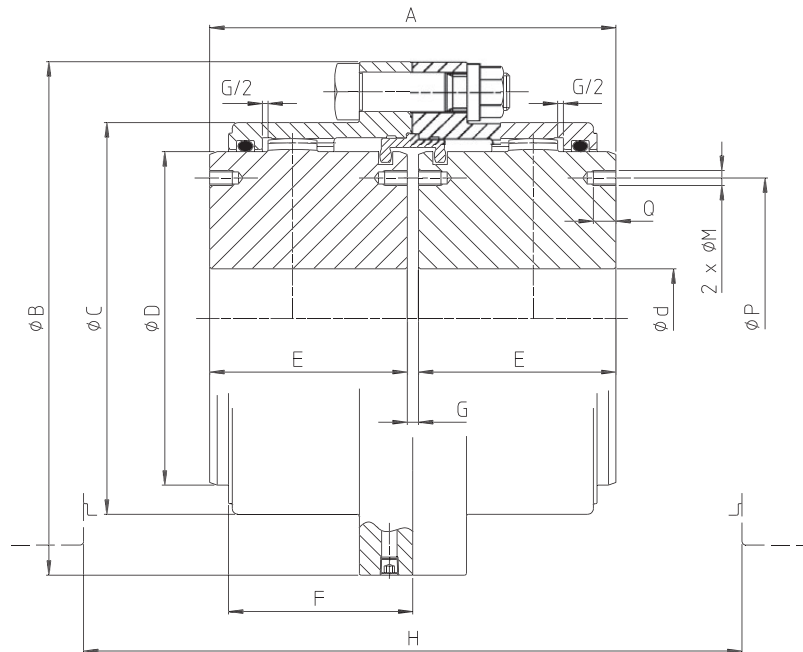

max.  
 NOUS CONSULTER  
 ONS RAADPLEGEN  
 REFER TO FACTORY  
 AUF ANFRAGE

		Type FLE												
		45	60	75	95	110	130	155	175	195	215	240	275	
 d Ø nominal max. d Ø min. * d Ø max	1	mm	45	60	75	95	110	130	155	175	195	215	240	275
		mm	0	0	0	0	0	55	65	80	90	100	120	150
		mm	50	64	78	98	112	132	158	175	198	217	244	290
 1m Nm Tn Tp	2	Nm	1300	2800	5000	10000	16000	22000	32000	45000	62000	84000	115000	174000
			2600	5600	10000	20000	32000	44000	64000	90000	124000	168000	230000	348000
 /min.max. 3.1 3.2	3	tr/min omw/min rpm min <sup>-1</sup>	5000	4400	4000	3600	3350	3100	2800	2700	25550	2450	2300	2150
			7000	6200	5650	5100	4700	4350	4000	3800	3600	3450	3300	3050
 J (WR <sup>2</sup> )	4	kgm <sup>2</sup>	0,005	0,015	0,040	0,105	0,191	0,430	0,842	1,32	2,45	3,72	5,38	10,87
	5	kg	4,1	8,0	14,6	26,1	38,8	59,2	89,4	118	167	222	275	414
 Grease	6	dm <sup>3</sup>	2x0,025	2x0,037	2x0,065	2x0,105	2x0,18	2x0,26	2x0,40	2x0,49	2x0,76	2x1,01	2x1,21	2x1,64
mm: ±	A	mm	89	103	127	157	185	216	246	278	308	358	388	450
	B	mm	117	141	171	210	234	274	312	337	380	405	444	506
	C	mm	80	103,5	129,5	156	181	209	247	273	307	338	368	426
	D	mm	67	87	106	130	151	178	213	235	263	286	316	372
	E	mm	43	50	62	76	90	105	120	135	150	175	190	220
	F	mm	41	47	58,5	68,5	82	98	108,5	121	132	151,5	165	183,5
	G	mm	3	3	3	5	5	6	6	8	8	8	8	10
	H	10 mm	147	166	212	249	295	350	392	440	484	562	616	688
	M	mm								M 12	M 16	M 16	M 16	M 20
P	mm								205	226	250	276	330	
Q	mm								18	24	24	24	30	

\* Consult us

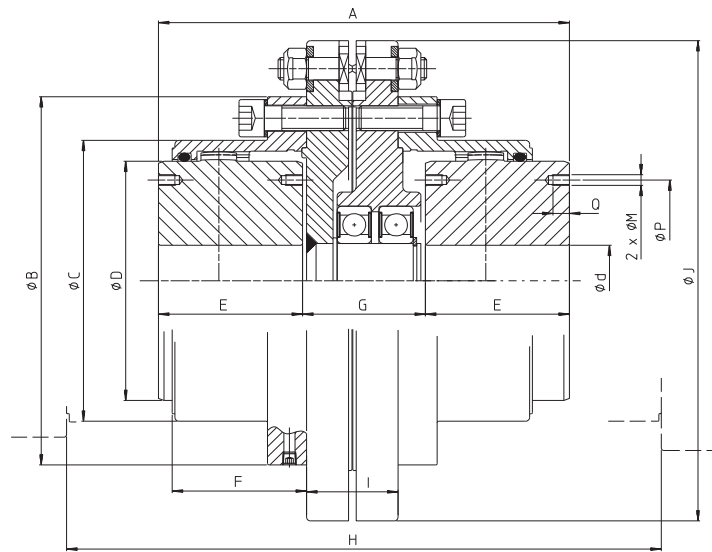

max. 1,5°

←A150			Type FSP												
			45	60	75	95	110	130	155	175	195	215	240	275	
	d Ø nominal max.	mm	45	60	75	95	110	130	155	175	195	215	240	275	
	d Ø min.	mm	0	0	0	0	0	55	65	80	90	100	120	150	
	*d Ø max.	mm	50	64	78	98	112	132	158	175	198	217	244	290	
	Tn	Nm	750	1800	3500	7000	11000	15500	22000	31500	43500	55000	81000	122500	
	1m Tp		1500	3600	7000	14000	22000	31000	44000	63000	87000	110000	162000	245000	
	min.max.	tr/min omw/min rpm min <sup>-1</sup>	4000	3600	3300	2950	2550	2150	2000	1800	1650	1450	1400	1350	
		degré graad degree Grad	2x0,75	2x0,75	2x0,75	2x0,75	2x0,75	2x0,75	2x0,75	2x0,75	2x0,75	2x0,75	2x0,75	2x0,75	
		mm: ±	0,6	0,7	0,8	0,9	1	1,2	1,3	1,4	1,5	1,9	2,0	2,3	
	J (WR <sup>2</sup> )	kgm <sup>2</sup>	0,019	0,055	0,098	0,272	0,448	1,01	1,75	2,77	4,61	6,82	9,68	18,4	
		kg	8,5	16,9	26,5	45,1	62,5	99,5	139	183	247	316	395	579	
		dm <sup>3</sup>	2x0,025	2x0,037	2x0,065	2x0,105	2x0,18	2x0,26	2x0,40	2x0,49	2x0,76	2x1,01	2x1,21	2x1,64	
mm: ±	A	mm	131	153	185	217	247	293	324	363	396	467	504	579	
	B	mm	111	141	171	210	234	274	312	337	380	405	444	506	
	C	mm	80	103,5	129,5	156	181	209	247	273	307	338	368	426	
	D	mm	67	87	106	130	151	178	213	235	263	286	316	372	
	E	mm	43	50	62	76	90	105	120	135	150	175	190	220	
	F	mm	41	47	58,5	68,5	82	98	108,5	121	132	151,5	165	183,5	
	G	9	mm	45	53	61	65	67	83	84	93	96	117	124	139
	H	10	mm	189	216	270	309	357	427	470	525	572	671	732	817
	I		mm	33	44	44	48	48	60	60	64	64	78	78	96
	J		mm	155	194	228	267	300	358	384	428	470	524	560	656
	M		mm								M 12	M 16	M 16	M 16	M 20
	P		mm								205	226	250	276	330
	Q		mm								18	24	24	24	30

\* Consult us

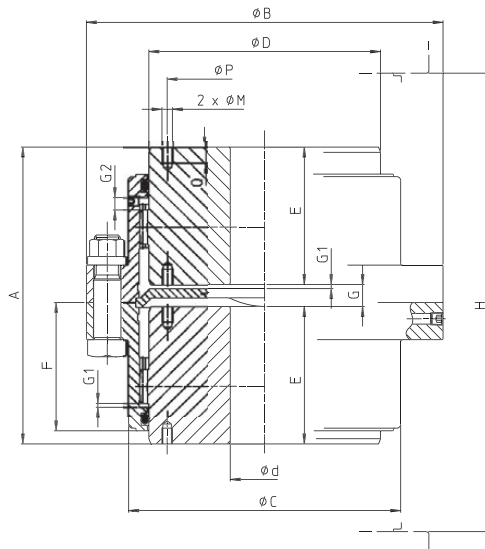

max. 1,5°

La cote G ne peut varier en cours de fonctionnement  
 Maat G mag niet gewijzigd worden bij werking  
 Distance G may not vary during operation  
 Das Maß "G" muß während des Betriebs konstant bleiben

←A150			Type FSV												
			45	60	75	95	110	130	155	175	195	215	240	275	
	d Ø nominal max.	mm	45	60	75	95	110	130	155	175	195	215	240	275	
	d Ø min.	mm	0	0	0	0	0	55	65	80	90	100	120	150	
	* d Ø max.	mm	50	64	78	98	112	132	158	175	198	217	244	290	
	Tn	Nm	1300	2800	5000	10000	16000	22000	32000	45000	62000	84000	115000	174000	
	1m Tp		2600	5600	10000	20000	32000	44000	64000	90000	124000	168000	230000	348000	
	tr/min omw/min rpm min <sup>-1</sup>		5000	4400	4000	3600	3350	3100	2800	2700	2550	2450	2300	2150	
	degré graad degree Grad		2x0,75	2x0,75	2x0,75	2x0,75	2x0,75	2x0,75	2x0,75	2x0,75	2x0,75	2x0,5	2x0,5	2x0,5	
	mm: ±		0,35	0,4	0,5	0,6	0,7	0,9	1	1,1	1,2	0,9	1	1,1	
	J (WR <sup>2</sup> )	kgm <sup>2</sup>	0,005	0,015	0,040	0,105	0,191	0,430	0,842	1,32	2,45	3,72	5,38	10,9	
		kg	4,1	8,0	14,6	26,1	38,8	59,2	89,4	118	167	222	275	414	
		dm <sup>3</sup>	2x0,021	2x0,037	2x0,057	2x0,104	2x0,164	2x0,254	2x0,387	2x0,514	2x0,741	2x0,940	2x1,12	2x1,69	
mm: ±	A	mm	94	105	136,5	163	193	224	255	287	320	377	414	468	
	B	mm	111	141	171	210	234	274	312	337	380	405	444	506	
	C	mm	80	103,5	129,5	156	181	209	247	273	307	338	368	426	
	D	mm	67	87	106	130	151	178	213	235	263	286	316	372	
	E	mm	43	50	62	76	90	105	120	135	150	175	190	220	
	F	mm	41	47	58,5	68,5	82	98	108,5	121	132	151,5	165	183,5	
	G	9	mm	8	5	12,5	11	13	14	15	17	20	27	34	28
	G1	9	mm	1,5	1,5	1,5	2,5	2,5	3	3	4	4	4	4	5
	G2	9	mm	5,5	5,5	6	8,5	8,5	12	12	16	16	16	16	20
	H	10	mm	147	166	212	249	295	350	392	440	484	562	616	688
	M		mm								M 12	M 16	M 16	M 16	M 20
	P		mm								205	226	250	276	330
	Q		mm								18	24	24	24	30

\* Consult us

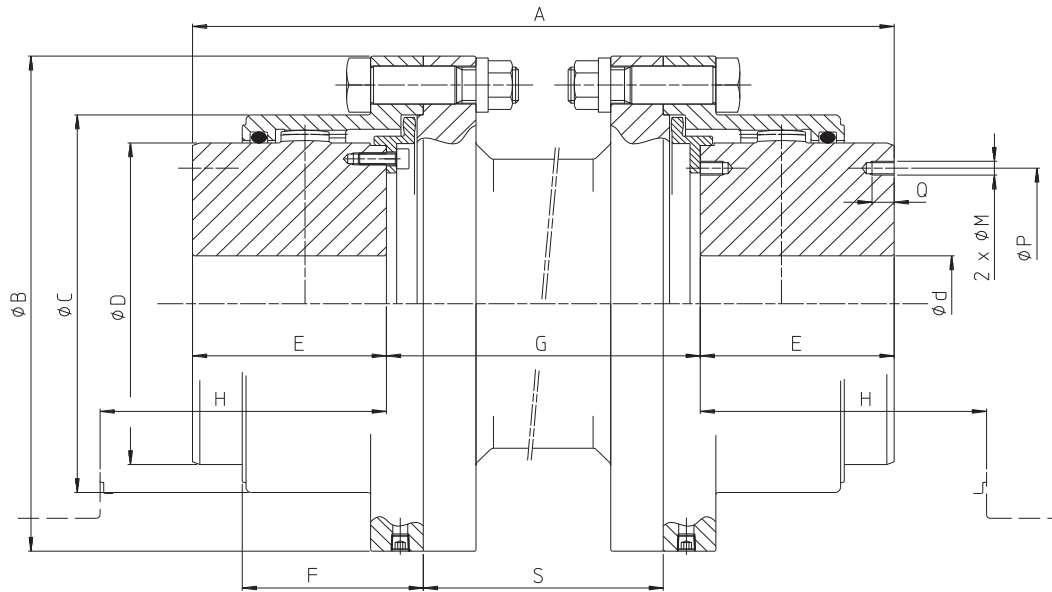





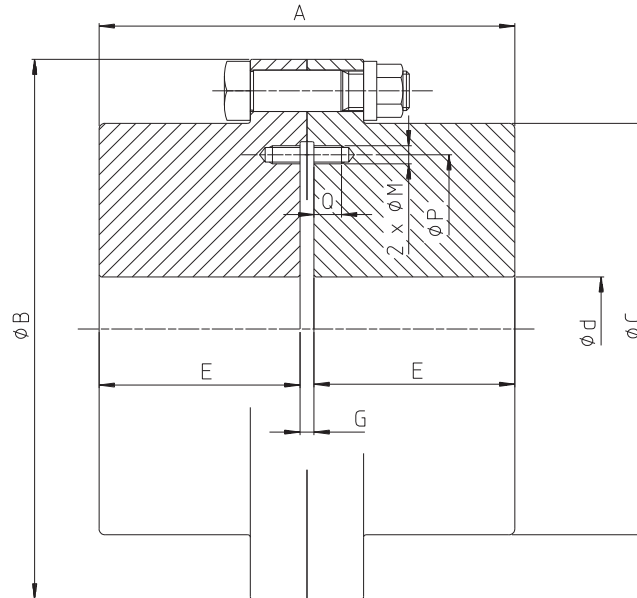

max.  
 NOUS CONSULTER  
 ONS RAADPLEGEN  
 REFER TO FACTORY  
 AUF ANFRAGE

←A150			Type FSLE												
			45	60	75	95	110	130	155	175	195	215	240	275	
d Ø nominal max. d Ø min. * d Ø max	1	mm	45	60	75	95	110	130	155	175	195	215	240	275	
		mm	0	0	0	0	0	55	65	80	90	100	120	150	
		mm	50	64	78	98	112	132	158	175	198	217	244	290	
1m Nm Tn Tp	2	Nm	1300	2800	5000	10000	16000	22000	32000	45000	62000	84000	115000	174000	
			2600	5600	10000	20000	32000	44000	64000	90000	124000	168000	230000	348000	
/min.max.	3.3	tr/min omw/min rpm min <sup>-1</sup>													
J (WR <sup>2</sup> )	4.1	kgm <sup>2</sup>													
	5.1	kg													
Grease	6	dm <sup>3</sup>	2x0,025	2x0,037	2x0,065	2x0,105	2x0,18	2x0,26	2x0,40	2x0,49	2x0,76	2x1,01	2x1,21	2x1,64	
mini  mm: ± mini	A	mm	167	195	245	291	323	380	412	450	516	580	624	676	
	B	mm	111	141	171	210	234	274	312	337	380	405	444	506	
	C	mm	80	103,5	129,5	156	181	209	247	273	307	338	368	426	
	D	mm	67	87	106	130	151	178	213	235	263	286	316	372	
	E	mm	43	50	62	76	90	105	120	135	150	175	190	220	
	F	mm	41	47	58,5	68,5	82	98	108,5	121	132	151,5	165	183,5	
	G	8	mm	81	95	121	139	143	170	172	180	216	230	244	236
	G1	mm	1,5	1,5	1,5	2,5	2,5	3	3	4	4	4	4	5	
	H	10	mm	63	76	91	110	131	155	175	195	214	246	266	306
	M	mm									M 12	M 16	M 16	M 16	M 20
mini	P	mm								205	226	250	276	330	
	Q	mm								18	24	24	24	30	
	S	8	mm	60	80	90	110	110	130	130	130	10	160	160	160

\* Consult us



 ←A150			Type FRR											
			45	60	75	95	110	130	155	175	195	215	240	275
	1	d Ø max.	55	75	95	110	130	155	180	200	230	250	280	330
		d Ø min.	0	0	0	0	0	55	65	80	90	100	120	150
	2	Tn	1300	2800	5000	10000	16000	22000	32000	45000	62000	84000	115000	174000
		TP	2600	5600	10000	20000	32000	44000	64000	90000	124000	168000	230000	348000
	3.3	tr/min omw/min rpm min <sup>-1</sup>	6000	5500	5000	4400	4000	3500	3000	2700	2500	2200	2100	2000
	4	J (WR <sup>2</sup> )	0,005	0,017	0,041	0,109	0,203	0,459	0,9	1,4	2,7	4,1	6,0	12,0
	5.1	kg	4,4	8,4	14,6	26,9	40,4	62,2	92,1	123	185	244	308	461
mini	A	mm	87	101	123	155	181	209	233	266	308	358	392	456
	B	mm	111	141	171	210	234	274	312	337	380	405	444	506
	C	mm	80	103,5	126	152	178	208	245	270	305	330	362	416
	E	mm	40	47	58	74	87	101	113	129	150	175	190	220
	G	mm	7	7	7	7	7	7	7	8	8	8	12	16
	M	mm								M 12	M 16	M 16	M 16	M 20
	P	mm								235	265	290	320	370
	Q	mm								18	24	24	24	30

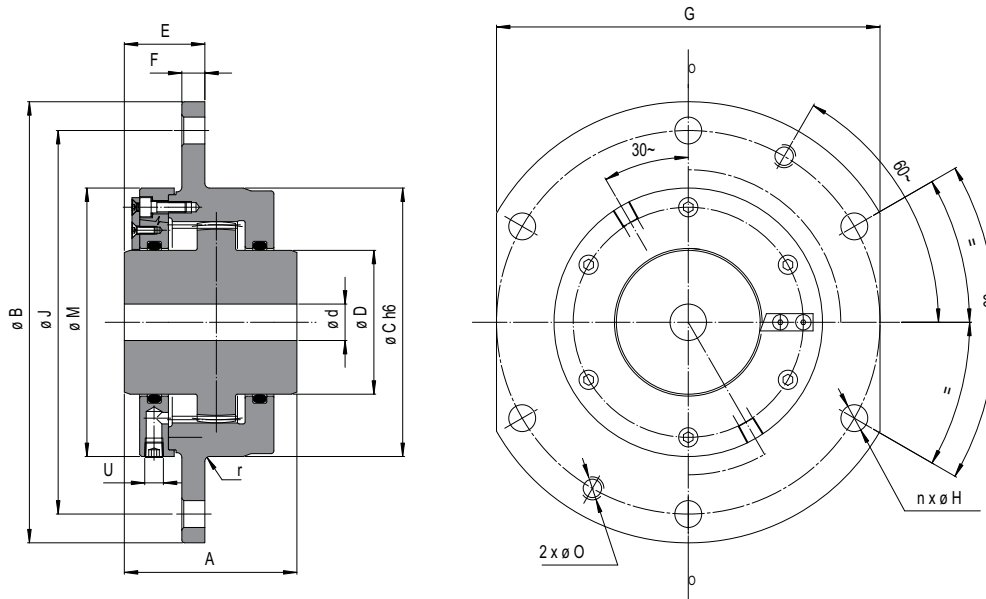

←A150	ESCO	150	170	220	250	280	300	320	380	420	
	SEB	SG130	SG140	SG185	SG200	SG240	SG270	SG315	SG355	SG400	
$\frac{d}{\text{max.}}$ $\frac{d}{\text{min.}}$	1	mm	150	170	220	250	280	300	320	380	420
		mm	65	80	120	150	180	190	200	220	260
$\frac{M}{1m}$ Tn Tp	2	kNm	37	62	130	160	310	385	500	660	800
		kNm	74	124	260	320	620	770	1000	1320	1600
RADIAL LOAD	—	kN	88	112	188	221	314	343	399	499	587
$\Delta K_w$	—	degré graad degree Grad	0,75	0,75	0,75	0,75	0,75	0,75	0,75	0,75	0,75
$\Delta K_a$	—	mm: ±	7	8	8	8	8	10	10	10	
$\frac{J}{(WR^2)}$	4	kgm <sup>2</sup>	0,78	1,69	4,7	6,4	13,6	18,1	25,2	42,2	62
	5	kg	69	105	198	235	370	460	560	760	940
	6	dm <sup>3</sup>	0,20	0,39	0,54	0,59	0,91	1,17	1,83	1,98	2,41
mm: ±	A	mm	170	185	240	260	315	350	380	410	450
	B	mm	400	450	550	580	650	680	710	780	850
	C	mm	280	340	420	450	530	560	600	670	730
	D	mm	220	240	320	350	410	440	470	536	580
	E	mm	45	60	60	60	65	65	81	81	81
	F	mm	15	20	20	20	25	25	35	35	35
	G	mm	360	400	500	530	580	600	640	700	760
	H	mm	19	24	24	24	24	24	28	28	28
	J	mm	360	400	500	530	600	630	660	730	800
	M	mm	279	339	419	449	529	559	599	669	729
	O	mm	M 16	M 20	M 20	M 20	M 20	M 20	M 20	M 20	M 20
	n	—	10	10	10	14	14	26	26	26	26
	r	mm	2,5	2,5	2,5	2,5	2,5	4	4	4	4
u	R"	1/8	1/4	1/4	1/4	1/4	1/4	1/4	1/4	1/4	

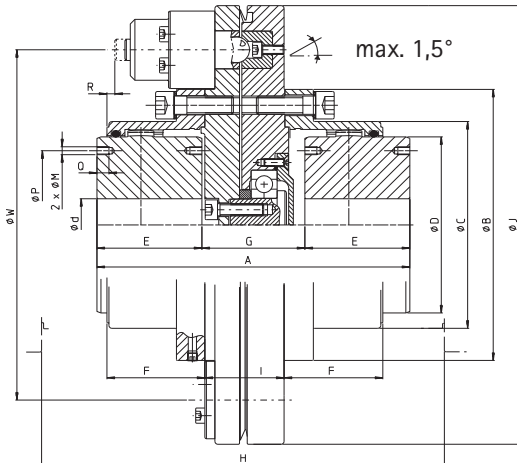

## TORQUE CONTROL DEVICES

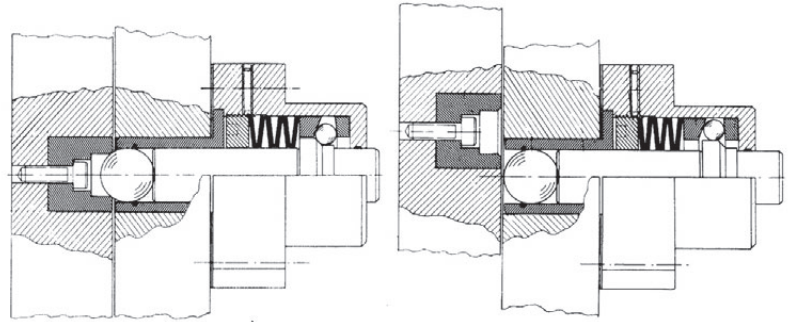

engagé - eingeschaltet - engaged

désengagé - ausgeschaltet - disengaged

←A150			Type FET											
			60/1	75/1	95/2	110/2	130/3	155/3	175/4	195/4	215/5	240/5	275/6	
	d Ø nominal max.	mm	60	75	95	110	130	155	175	195	215	240	275	
		d Ø min.	mm	0	0	0	0	55	65	80	90	100	120	150
		* d Ø max.	mm	64	78	98	112	132	158	175	198	217	244	290
	Tn	Nm	2800	5000	10000	16000	22000	32000	45000	62000	84000	115000	174000	
		min.	Nm	1010	1010	1930	1930	7140	7140	11320	11320	34900	34900	57600
		max.		5600	8180	15600	15600	44000	57200	90000	90750	168000	230000	348000
	/min.max.	tr/min	3600	3300	2950	2550	2150	2000	1800	1650	1450	1400	1350	
		omw/min rpm min <sup>-1</sup>												
	α	degré	2x0,75	2x0,75	2x0,75	2x0,75	2x0,75	2x0,75	2x0,75	2x0,75	2x0,75	2x0,75	2x0,75	
		graad degree Grad												
	mm: ±		0,7	0,8	1	1,1	1,4	1,5	1,7	1,8	2,2	2,3	2,7	
	J (WR <sup>2</sup> )	kgm <sup>2</sup>	0,271	0,323	0,733	0,862	3,84	4,59	7,83	9,28	26,4	31,6	58,9	
	kg		33,1	41,6	67,9	82,5	184	222	290	345	587	681	1017	
	dm <sup>3</sup>		2x0,037	2x0,065	2x0,105	2x0,18	2x0,26	2x0,40	2x0,49	2x0,76	2x1,01	2x1,21	2x1,64	
mm: ±	A	mm	161	193	228	258	325	356	391	424	512	549	630	
	B	mm	141	171	210	234	274	312	337	380	405	444	506	
	C	mm	103,5	129,5	156	181	209	247	273	307	338	368	426	
	D	mm	87	106	130	151	178	213	235	263	286	316	372	
	E	mm	50	62	76	90	105	120	135	150	175	190	220	
	F	mm	47	58,5	68,5	82	98	108,5	121	132	151,5	165	183,5	
	G	mm	61	69	76	78	115	116	121	124	162	169	190	
	H	10	mm	224	278	320	368	459	502	553	600	716	777	868
	I	mm	52	52	59	89	92	92	92	92	123	123	147	
	J	mm	288	288	350	350	464	464	538	538	706	706	844	
	M	mm								M 12	M 16	M 16	M 16	M 20
	P	mm								205	226	250	276	330
	Q	mm								18	24	24	24	30
	R	mm		- 9,5	1	16	28,5	13	20,5	35	45	12,5	37	80,5
	W	mm		230	230	292	292	390	390	464	464	582	582	720

\* Consult us

Caractéristiques principales – Voornaamste karakteristieken – Main features – Viktiga fördelar  
 Charakteristische Hauptmerkmale – Caracteristicas principales – Caratteristiche principali

- 3 POSITIONS MOYEUX
- 3 NAVENPOSITIES
- 3 HUBS POSITIONS
- 3 EINBAUMÖGLICHKEITEN
- 3 NAVKOMBINATIONER
- 3 POSICIONES CUBO
- 3 POSIZIONI DEI MOZZI

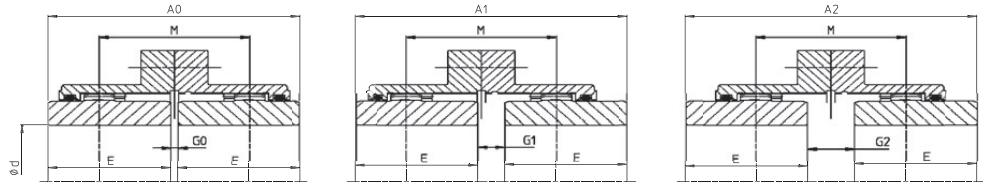

←A105 		Type FST																
		45	60	75	95	110	130	155	175	195	215	240	275	280*	320*	360N*	400N*	450N*
d Ø nominal max.	mm	45	60	75	95	110	130	155	175	195	215	240	275	280	320	360	400	450
d Ø min.	mm	0	0	0	0	0	55	65	80	90	100	120	150	180	200	220	260	280
*d Ø max.	mm	50	65	78	98	112	132	158	175	198	212	244	290	310	340	390	435	485
A0	mm	89	103	127	157	185	216	246	278	308	358	388	450	570	597	623	673	713
A1	mm	98	109	141	169	199	233	264	299	332	389	426	483	590	617	658	713	761
A2	mm	107	115	155	181	213	250	282	320	356	420	464	516	610	637	693	753	809
E	mm	43	50	62	76	90	105	120	135	150	175	190	220	280	292	305	330	350
G0	mm	3	3	3	5	5	6	6	8	8	8	8	10	10	13	13	13	13
G1	mm	12	9	17	17	19	23	24	29	32	39	46	43	30	33	48	53	61
G2	mm	21	15	31	29	33	40	42	50	56	70	84	76	50	53	83	93	109
M	mm	55	59	79	93	109	128	144	164	182	214	236	263	310	325	353	383	411

\*Consult us

4 ALTERNATIVES – 4 ALTERNATIEVEN – 4 ALTERNATIV – 4 AUSFÜHRUNGEN – 4 ALTERNATIVAS – 4 ALTERNATIVE

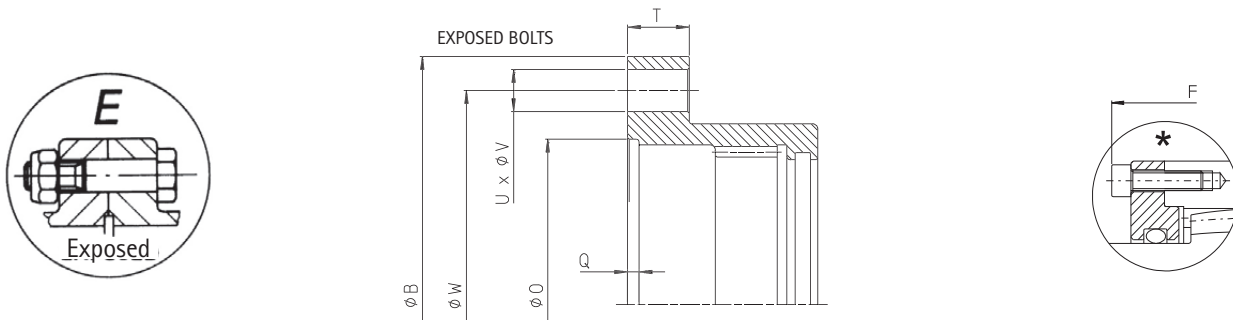

Type ⇨		(1)	(1 1/2)	(2)	(2 1/2)	(3)	(3 1/2)	(4)	(4 1/2)	(5)	(5 1/2)	(6)	(7)	(8)*	*	*	*	*
		45	60	75	95	110	130	155	175	195	215	240	275	280*	320*	360N*	400N*	450N*
Flange Connection	B mm	111	141	171	210	234	274	312	337	380	405	444	506	591	640	684	742	804
	O mm	78	100	120	144	170	198	234	256	290	315	345	400	451	483	540	590	660
	Q mm	3,5	3,5	3,5	3,5	3,5	3,5	3,5	4	4	4	6	8	8	8	8	10	10
	T mm	14	19	19	22	22	28,5	28,5	28,5	38	38	26	28,5	33	38	38	38	38
Exposed Metric (E.M.)	U Qty.	6	8	6	6	8	8	8	10	10	14	14	16	14	18	24	28	30
	V mm	9	11	13	17	17	21	21	21	21	21	25	25	32	32	32	32	32
	W mm	96	122	150	184	208	242	280	305	345	368	406	460	530	580	624	682	744
Exposed Inch (E.I.)	U Qty.	6	8	6	6	8	8	8	10	8	14	14	16	16				
	V inch.	0,250	0,375	0,500	0,625	0,625	0,750	0,750	0,750	0,875	0,875	0,875	1,000	1,125				
	W inch.	3,750	4,812	5,875	7,125	8,125	9,5	11	12	13,5	14,5	15,75	18,25	20,75				

## SERIE F

### TABLE OF CONTENTS

1. Introduction
2. Preparation
3. Warnings
4. Assembly
5. Inspection and maintenance

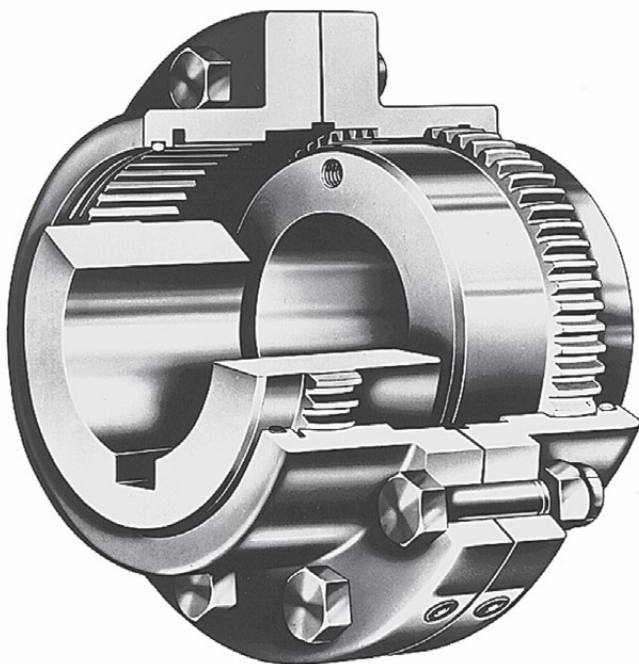

INSTALLATION & MAINTENANCE

## 1. INTRODUCTION --- English

Coupling must be selected properly according to selection chart A 150 and corresponding charts. These documents are available in coupling catalogue ESCOGEAR FST or on our web site «www.esccoupling.com». Maximum misalignment figures at assembly are given in this document (see point 4: assembly). Max misalignment figures in operation are given in ESCOGEAR FST catalogue. Max misalignment, max speed and max torque may not be applied simultaneously as mentioned in selection chart A 150. In case of any change or adaptation not performed by ESCO on the coupling, it is customer responsibility to size and manufacture it properly to guarantee safe torque transmission and absence of unbalance that could affect the life of the coupling and the connected machines. It is customer responsibility to make sure that shaft and key material, size and tolerance suit the application. Maximum bore capacity is given in the catalogue. If key assembly is not calculated and machined by ESCO, it is customer responsibility to make sure that hub length, bore size and machining tolerances will transmit the torque. If interference fit is not calculated and machined by ESCO, it is customer responsibility to make sure that interference and machining tolerances will transmit the torque and not exceed hub material permissible stress. The hubs must be axially secured on the shaft by means of a setscrew, an end plate or a sufficient interference. In case of spacer or floating shaft not supplied by ESCO, it is customer responsibility to size and manufacture it properly to guarantee safe torque transmission and absence of unbalance that could affect the life of the gearing. It is customer responsibility to protect the coupling by p.ex. a coupling guard and to comply with the local safety rules regarding the protection of rotating parts.

## 2. PREPARATION

Ensure the conformity of the supplied equipment:

--- **Verify coupling size and conformity (see catalogue or web site).** --- **Identify any damaged and/or missing parts.**

--- **Verify conformity of the coupling/machine interfaces.**

Coupling original protection allows for storage indoors dry 18 months, indoors humid 12 months, outdoors covered: 9 months and outdoors open: 3 months. For longer periods, it is customer responsibility to protect the parts properly. Instructions are a part of the supply of the coupling. Be sure valid and complete assembly, operation and maintenance instructions are available. Make sure they are well understood. In case of doubt, refer to ESCO. Assembly, disassembly and maintenance must be performed by qualified, trained and competent fitters. Before starting with assembly, disassembly and maintenance, verify the availability of the tooling necessary

--- To manipulate the parts --- To assemble the interfaces --- To align the coupling --- To tighten the screws and nuts.

## 3. WARNINGS

Before removing the coupling guard and proceeding with any assembly, operation or maintenance operation of the coupling, make sure the complete system is completely shut down and definitively disengaged from any possible source of rotation, such as, for example:

--- Electrical power supply. --- Any loss of braking effect.

Make sure everyone attending the equipment area will be properly informed (for example by means of warnings properly located) about the maintenance or assembly situation. In case of use in explosive atmospheres  $\langle \text{Ex} \rangle$ , specific protective measures must be considered. They are described in an extra attachment (IM/A200-Ex) to the actual instructions with the couplings marked  $\langle \text{Ex} \rangle$ .

## 4. ASSEMBLY

### 4.1 Coupling without end-cap

4.1.1 Ensure all parts are clean.

4.1.2 Apply a light coat of grease to the O-Rings A and insert O-Rings into grooves J of sleeves B.

4.1.3 Place sleeves B over shaft ends. Care should be taken not to damage O-Rings A.

4.1.4 Install hubs C on their respective shafts with the longest hub end towards shaft end or towards machine bearing depending on the type (see fig. 1 and 3). If needed, for keyway assembly, uniformly heat hubs C (max 120°C) to install them easily on the shaft, in this case, avoid any contact between the hub C and O-Ring A. Hub faces have to be flush with shaft end. In case of doubt, please consult us. Introduce setscrew on key with Loctite and tighten properly. In case of interference fit, refer to ESCO for proper instructions.

4.1.5 Install units to be connected in place and check the spacing G between hubs. See tabulation or approved drawing for correct hub spacing G, according to coupling size. In case of doubt, please consult us.

4.1.6 Align the two shafts, check alignment using an indicator. For alignment precision: see tabulation 4.

4.1.7 Coat hub and sleeve gearings with grease (see tabulation 3) and slide sleeves B over hubs.

4.1.8 Insert gasket F and bolt sleeves together. Tighten bolts uniformly. See tabulation 2 for correct tightening torque (T1 Nm). Make sure that sleeves are freely sliding over hubs by axially displacing it to a value equal to G (see tabulation 1).

4.1.9 For the types FST, FMM and FDMM, remove both lube plugs H of one sleeve B and add grease in sufficient amount to overflow with lubricant holes in horizontal position. For the types FFS, FSE, FSLE, FLE, FSP, FIN and FSV repeat this operation for the second sleeve. For quantity and quality of grease, see tabulation 3. Re-install the 2 plugs H; see tabulation 2 for correct tightening torque (T3 Nm) and key size (s mm). For type FSV consult us.

### 4.2 Coupling with end-cap

4.2.1 Ensure all parts are clean.

4.2.2 Apply a light coat of grease to the O-Rings A and insert O-Rings into grooves J of end-cap X.

4.2.3 Place end-cap x and gasket xx over shaft ends. Care should be taken not to damage O-Rings A.

4.2.4 Install hubs C on their respective shafts with the longest hub end towards shaft end or towards machine bearing depending on the type (see fig. 2 and 3). If needed, for keyway assembly, uniformly heat hubs C (max 120°C) to install them easily on the shaft. In this case, avoid any contact between the hub C and O-Ring A. Hub faces have to be flush with shaft end. In case of doubt, please consult us. Introduce setscrew on key with Loctite and tighten properly. In case of interference fit, refer to ESCO for proper instructions

4.2.5 Install units to be connected in place and check the spacing G between hubs. See above tabulation or approved drawing for correct hub spacing G, according to coupling size. In case of doubt, please consult us.

4.2.6 Align the two shafts, check alignment using an indicator. For alignment precision: see tabulation 4.

4.2.7 Coat hub and sleeve gearings with grease (see tabulation 3) and slide sleeves B over hubs. Assemble end-caps K and gaskets L on sleeves B with screws M and locking rings. Tighten screws uniformly. See tabulation 2 for correct tightening torque (T2 Nm) and key size (s mm).

4.2.8 Insert gasket F and bolt sleeves together. Tighten bolts uniformly. See tabulation 2 for correct tightening torque (T1 Nm) and socket size. Make sure that sleeves are freely sliding above hubs by axially displacing it to a value equal to G.

4.2.9 For the types FST, FMM and FDMM, remove both lube plugs H of one sleeve B and add grease in sufficient amount to overflow with lubricant holes in horizontal position. For the types FFS, FSE, FSLE, FLE, FSP, FIN and FSV repeat this operation for the second sleeve. For quantity and quality of grease, see tabulation 3. Re-install the 2 plugs H; see tabulation 2 for correct tightening torque (T3 Nm) and key size (s mm). For type FSV consult us.

## 5. INSPECTION and MAINTENANCE

### 5.1 Inspection

Regular inspection (audio-visual) must occur for leakage, noise, vibration and loss of parts.

### 5.2 Maintenance

5.2.1 Every 4.000 hours or every year

Check that sleeves are freely moving axially: follow instructions as indicated in Point 4.1.8 or 4.2.8.

Fill up grease level: Proceed as mentioned under 4.1.9. or 4.2.9

5.2.2 Every 8.000 hours or every 2 years.

-- Remove screws and nuts and gasket F. -- Clean and control gearing and sealing.

-- Control alignment See Point 4.1.6 or 4.2.6. -- Reassemble coupling as per Point 4. It is recommended to replace gasket F and screws and nuts at every reassembly.

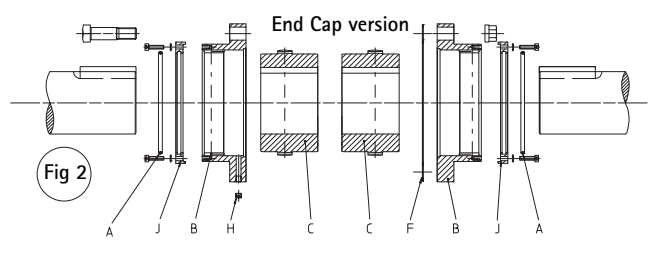
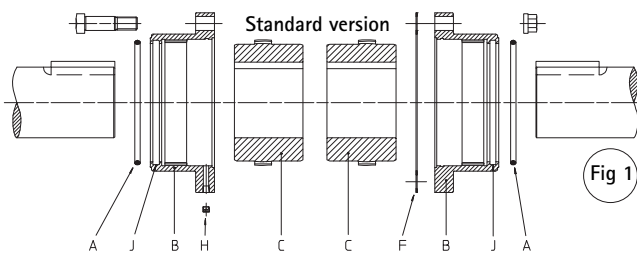

Fig 1

Fig 2

Type	FST FMM FDMM FLE G mm	FFS G mm	FSP G mm	FSH (min.) G mm	FSV G mm	FRR G mm	FET G mm	FIN G mm
45	3	2 x 5	45	8	8	7		
60	3	2 x 5	53	8	5	7	61	7
75	3	2 x 5	61	8	12,5	7	69	8
95	5	2 x 6	65	10	11	7	76	11
110	5	2 x 6	67	10	13	7	78	11
130	6	2 x 6,5	83	11	14	7	115	12
155	6	2 x 6,5	84	11	15	7	116	12
175	8	2 x 8	93	14	17	8	121	14
195	8	2 x 8	96	14	20	8	124	14
215	8	2 x 8	117	16	27	8	162	14
240	8	2 x 10	124		34	12	169	16
275	10	2 x 13	139		28	16	190	
280	10	2 x 13						
320	13	2 x 14,5						
360 N	13							
400 N	13							
450 N	13							

Type	Flange						End Cap			Plug	
	Exposed Metric bolts			Exposed Inches bolts			T 2	Exagonal socket head screws		T3	s
	T 1	Socket Size mm	Driver inch	T 1	Socket Size mm	Driver inch		M mm	s inch		
45	33,5	10	1/4"	15	3/8"	1/4"				7	4
60	66	12	3/8"	49	1/2"	3/8"				10	5
75	112	14	3/8"	118	5/8"	1/2"	4	4	3	10	5
95	277	19	1/2"	236	25/32"	1/2"	8	5	4	10	5
110	277	19	1/2"	236	25/32"	1/2"	8	5	4	10	5
130	537	24	1/2"	413	15/16"	1/2"	8	5	4	10	5
155	537	24	1/2"	413	15/16"	1/2"	8	5	4	10	5
175	537	24	1/2"	413	15/16"	1/2"	13	6	5	10	5
195	537	24	1/2"	569	17/16"	1/2"	13	6	5	10	5
215	537	24	1/2"	569	17/16"	1/2"	33	8	6	29	8
240	795	30	3/4"	569	17/16"	1/2"	33	8	6	29	8
275	795	30	3/4"	795	19/16"	3/4"	33	8	6	29	8
280	1855	46	1"				65	10	8	29	8
320	1855	46	1"				65	10	8	29	8
360N	1855	46	1"				65	10	8	29	8
400N	1855	46	1"				112	12	10	29	8
450N	1855	46	1"				112	12	10	29	8

For FIN and FWD types, refer to factory

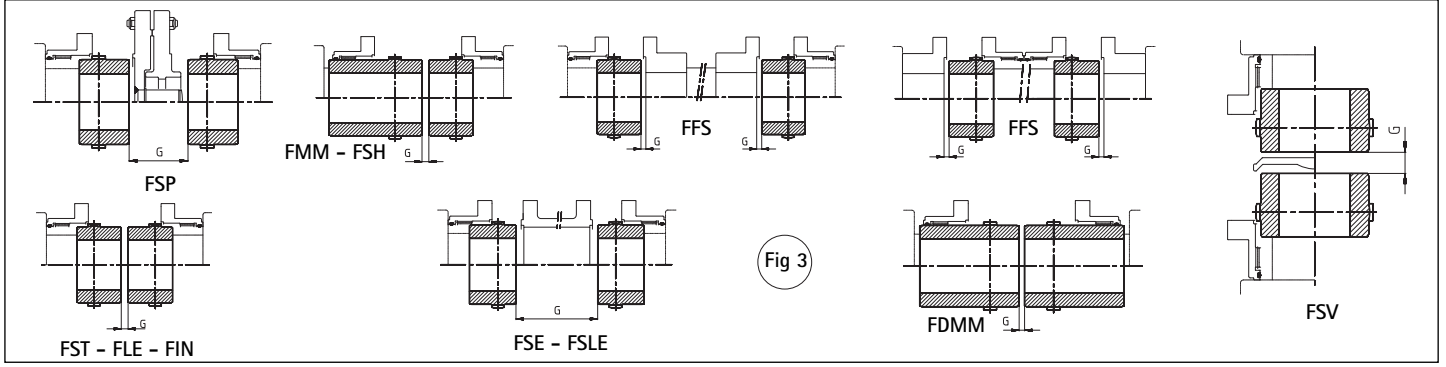

Fig 3

NORMAL SPEED AND DUTY		HIGH SPEED, HEAVY DUTY AND ATEX		Type	FST FMM FDMM dm³	FFS FSE FSLE dm³	FLE FSP FIN dm³	FSV dm³	FSH	FWD
Agip	Agip GR MV/EP 1	Caltex	Coupling Grease	45	0,047	2 x 0,025	2 x 0,025	2 x 0,021		
Caltex	Coupling Grease	Klüber	Klüberplex GE 11-680	60	0,074	2 x 0,037	2 x 0,032	2 x 0,037		
Castrol	Impervia MDX	Mobil	Mobilgrease XTC	75	0,131	2 x 0,065	2 x 0,062	2 x 0,057		
Chevron	Polyurea grease EPO	Shell	Albida GC1	95	0,207	2 x 0,105	2 x 0,117	2 x 0,104		
Esso	Fibrax 370	Texaco	Coupling Grease	110	0,362	2 x 0,180	2 x 0,170	2 x 0,164		
Fina	Marson EPL 1			130	0,522	2 x 0,260	2 x 0,230	2 x 0,254		
Kübler	Klüberplex GE 11-680			155	0,796	2 x 0,400	2 x 0,450	2 x 0,387		
Mobil	Mobilux EPO			175	0,976	2 x 0,490	2 x 0,610	2 x 0,514		
Q 8	Rembrandt EPO			195	1,513	2 x 0,760	2 x 0,820	2 x 0,741		
Shell	Alvania grease EP R-0 or EP 1			215	2,017	2 x 1,010	2 x 1,200	2 x 0,940		
Texaco	Coupling Grease			240	2,429	2 x 1,210	2 x 1,300	2 x 1,120		
Total	Specis EPG			275	3,286	2 x 1,640	2 x 1,900	2 x 1,690		
				280	6,440	2 x 3,220	2 x 3,200			
				320	7,600	2 x 3,800	2 x 3,800			
				360N	11,000	2 x 5,500	2 x 5,500			
				400N	12,000	2 x 6,000	2 x 6,000			
				450N	16,000	2 x 8,000	2 x 8,000			

FST	K <sub>x0</sub>	K <sub>y0</sub>
45	1,92	2,34
60	2,06	3,04
75	2,76	3,71
95	3,25	4,54
110	3,80	5,28
130	4,47	6,22
155	5,03	7,55
175	5,72	8,20
195	6,35	9,18
215	7,47	9,98
240	8,24	11,04
275	9,18	12,98
280	10,82	13,76
320	11,34	15,08
360	12,32	16,76
400	13,37	18,50
450	14,35	20,74

TABULATION 4 : ALIGNMENT PRECISION

Alignment is measured as shown on the figure (Y - Z) for angular and X for offset. Combination of angular and offset misalignment must comply with the following formulation:

$$\Delta K_{Wmin} \leq \frac{X}{K_x} + \frac{Y-Z}{K_y} \leq 0,75 \times \Delta K_{Wmax}$$

$\Delta K_W \min = 0,1^\circ$   
 $\Delta K_W \max$  depends on speed and torque as shown on graph (T, n) in coupling catalogue on page A150 E (a).

$$K_x = K_{x0} + \frac{S}{30} \text{ with } S = \text{Spacer length (mm)}$$

(If no spacer: S = 0)

$$K_y = K_{y0}$$

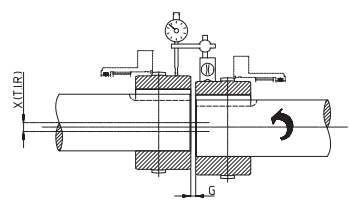
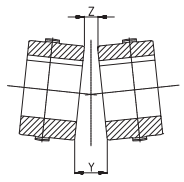

## Attachment $\text{Ex}$ : Specific Protective Measures Taken for ESCOGEAR Couplings in case of use in explosive atmospheres.

### 0 Introduction - English

General assembly and maintenance instructions (called IM in this attachment), are established for standard ESCOGEAR couplings according to the following list:

IM/A200 for ESCOGEAR NST couplings - IM/A300 for ESCOGEAR CST couplings  
IM/B300 for ESCOGEAR CST-M couplings - IM/B400 for ESCOGEAR FST couplings

In case of use in potentially explosive atmospheres, further to the general assembly and maintenance instructions (IM/...), the specific measures described in this attachment must be taken.

### 1 Coupling Selection

The coupling must be selected according to the general assembly and maintenance instructions IM/...

In explosive atmosphere  $\text{Ex}$ , the following specific rules must apply:

- A Service Factor of 2 must be applied on the max torque values given in the charts in catalogue (see Selection chart A 150).
- A Service Factor of 2 must be applied on the reference torque values given on the selection chart A150 for the calculation of max misalignment in operation.
- Max misalignment (combination of angular and offset) may not exceed 0.5° per gear mesh.

### 2. Use of the coupling

The coupling is dedicated for use in potentially explosive atmospheres according to European Directive 94/9/EC (Atex 100A). Coupling is classified in equipment group II, equipment category 2 and 3, intended for use in areas in which explosive atmospheres caused by gases, vapours, mists of air/dust mixtures are likely to occur. In function of the ambient temperature in the coupling proximity (65, 55, 40°C), the temperature classes have been defined (T4, T5, T6). This is based on a temperature increase of the machine shafts (in regard of the ambient temperature) that will not exceed 40°C in operation.

The coupling is marked as follows: CE  $\text{Ex}$  II 2 G T4/T5/T6 D 105°C -20°C ≤ Ta ≤ 65°C / 55°C / 40°C

This marking covers the T3 temperature category.

This marking covers all gas categories: G IIA, G IIB and G IIC

### 3. Warnings

The warnings mentioned in the general assembly and maintenance instructions IM/... must apply in any case.

In explosive atmosphere, the following specific warnings must apply:

- Complete machining of the coupling parts (bores, keyways, spacers, floating shafts etc...) must be performed by ESCO Couplings N.V. No modification shall be made on the supplied and marked product without the agreement of ESCO Couplings N.V.
- In case of supply by ESCO Couplings of couplings with a rough bore or a solid bore, the sole allowed operation that may be performed by the customer is the boring and keywaying of the coupling hubs. When machining the bore and the keyway, the following instructions must be followed:
  - This job must be performed by an authorised and adequately trained and informed operator.
  - The bore and keyway tolerances must be selected to insure the proper fit between shaft and bore. In case of loose fit, a set screw must be foreseen to locate the hub axially.
  - The max bore may not exceed the value stated in the catalogue. The tabulated values in the catalogue are based on key dimensions according to ISO R 773.
  - The reference used to centre the piece when boring, is the one referenced D in the figures of the catalogue.
- Before proceeding with any assembly, operation or maintenance operation on the coupling, make sure that the necessary measures have been taken to ensure safety, such as but not limited to:
  - Proper ventilation of the area
  - Proper lightening and electrical tools.
- If hub must be heated for assembly on the shaft, make sure heating source and surface temperature will not affect the safety of the working area.
- It is recommended to have a strong coupling guard, preferably in stainless steel with openings (if any) smaller than the smallest centrifugable part (plug is 6 mm dia). The coupling guard is intended to protect the environment from the centrifugation of any rotating part and the rotating coupling from any falling part. To limit ventilation effects, distance between cover and coupling outside surface should be at least 10 mm.

### 4. Assembly

The general assembly and maintenance instructions IM/... must apply in any case.

In explosive atmosphere, the following specific instructions must apply:

- Alignment of the machine in cold condition must take into account the possible heat expansion to make sure that in continuous running conditions, max misalignment calculated in point 1 will not be exceeded.
- Max misalignment may never exceed 0.5° per gear mesh.
- To improve the coefficient of friction and the leakage resistance, use following lubricants dedicated for gear couplings:
  - TEXACO Coupling Grease
  - CALTEX Coupling Grease
  - KLÜBER Klüberplex GE 11-680
  - SHELL Albida GC1

### 5. Operation

The general assembly and maintenance instructions IM/... must apply in any case.

In explosive atmosphere, the following specific instructions must apply:

- Before Start-up
  - Make sure coupling is perfectly aligned and clean.
  - Coupling guard must be properly installed and fixed.
  - Make sure, screws, nuts and plugs are properly tightened.
  - Monitoring system, if any, must be tested to verify its effectiveness.
- During start up
  - Check for any leakage. In case of abnormal leakage, immediate stop is recommended.
  - Check for any abnormal noise and/or vibration. If any, immediate stop is recommended.
- Checking intervals during operation
  - After the first 2000 hours or 6 months: check
    - for leakage, noise, vibration and loss of parts.
    - for free axial movement of the sleeves in regard of the hubs.
  - After 4000 hours or one year
    - for leakage, noise, vibration and loss of parts.
    - for free axial movement of the sleeves in regard of the hubs.
- Continuous checking
  - Immediately stop the machine if noise, vibrations or other abnormal phenomena are detected during operation.
  - Further more, if direct check is not possible for access or safety reasons, proper monitoring system has to be installed to follow up couplings behaviour

### 6. Maintenance

The general assembly and maintenance instructions IM/... must apply in any case.

In explosive atmosphere  $\text{Ex}$ , the following specific instructions must apply:

- Every 6.000 hours or 1.5 year:
  - Dismount the coupling and inspect.
  - Proceed as indicated in point 4.



24 HR TOLL-FREE EMERGENCY  
BRANCH HELPLINE:

**0800 022 224**

WEBSITE:

**[www.bmgworld.net](http://www.bmgworld.net)**



BEARING MAN GROUP

BEARINGS • SEALS • POWER TRANSMISSION • BELTING  
DRIVES & MOTORS • FASTENERS • FILTRATION • HYDRAULICS

ISO 9001 Certified